



model 1001MS

Barrier-Free Wall Mount Fountain

FEATURES & BENEFITS

CONSTRUCTION

Barrier-free design with an 18-gauge Type 304 satin finished stainless steel swirl bowl assembly mounted on a 14-gauge Type 304 stainless steel wall bracket. Unit includes an in-wall mounting frame, and front panel access for P-trap and stop.

QUALITY CONTROL

Pre-built fountain is pressure tested to ensure no leaks and proper functionality.

MOUNTING

Galvanized frame and 10 gauge surface plate provide the maximum mounting strength for the single bubbler drinking fountains.

BUBBLER HEAD

Polished chrome-plated brass bubbler head with integral laminar flow prevents splashing while providing a superior flow pattern. The integral 11/16" dia. basin shank and stainless anti-rotation roll pin for vandal resistance strength. Shielded, angled stream opening provides a steady source of drinking water at .45 gpm.

DRINKING FOUNTAIN VALVE

The push-button activated valve offers the only all stainless steel valve body that is machined out of solid bar stock, is fully serviceable through the front of the push button assembly offering access to the water control cartridge and integral water supply strainer, and with front access to the water stream height adjustment for easy maintenance without having to remove the valve. Operating pressure range of 30 to 90 psi (2.1 to 6.2 bar).

FOUNTAIN PUSH BUTTON

All chrome plated brass push button resists vandalism by allowing it to spin without unscrewing.



SPECIFICATIONS

Model 1001MS wall mounted barrier-free drinking fountain shall include an 18 gauge Type 304 Stainless Steel satin finish basin with integral swirl design, 14 gauge Type 304 Stainless Steel wall bracket, 100% lead-free waterways, stainless steel satin finish back and access panel allowing for front access of P-trap and stop, in-wall mounting frame, push-button operated stainless steel valve with front-accessible cartridge and flow adjustment, polished chrome-plated brass vandal-resistant bubbler head with integral laminar anti-squirt flow, chrome-plated brass vandal-resistant waste strainer, vandal-resistant bottom plate, and 1-1/4" O.D. (3.2 cm) waste pipe
REQUIRES MODEL MTGFR.DF1 PRICED SEPARATELY.

OPTIONS

- Remote Drinking Fountain Water chiller: Model HCR8, 8 gph (30.3 L) remote water chiller provides instantaneous cooling to meet a continuous demand for chilled water.
- Bottle Filler: Model 1920, bottle filler can be a stand-alone station, or mounted above Haws 1001, 1011, 1107L, 1109, 1117L, and 1119 series drinking fountain models.
- Back Panel: Model BP15, satin finish stainless steel 15 inch back panel for Model 1920.
- Water Filter: Model 6426, 10" x 2" (25.4 x 5.1 cm), in-line lead removal element that reduces lead from incoming water supply.

For more information, visit www.hawsco.com or call (888) 640-4297.

APPLICATIONS

Perfect for either public or private indoor/outdoor settings, Model 1001MS is a great fit in areas where aesthetics are important to the overall appeal of the architecture. This series is precisely mounted, making it a nice addition to any surrounding. Beautiful satin finish helps to maintain the fountains overall appeal so it always remains looking as new as it did when it was installed. Specifically, this type of wall mounted drinking fountain may be placed in settings such as: schools and other locations in and around office buildings where the temperature remains above freezing. Model meets all current Federal Regulations for the disabled including those in the Americans with Disabilities Act. Haws manufactures drinking fountains and electric water coolers to be lead-free by all known definitions including NSF/ANSI Standard 61, Section 9, NSF/ANSI 372, California Proposition 65, and the Federal Safe Drinking Water Act. Product is compliant to California Health and Safety Code 116875 (AB 1953-2006).



NOTES:

1. HOLD ROUGH-IN DIMENSIONS ± 1/8" (3.2mm).
2. WHEN INSTALLING THIS UNIT, LOCAL, STATE, OR FEDERAL CODES SHOULD BE ADHERED TO FOR INSTALLATION DIMENSIONS (LOCATIONS), WASTE AND SUPPLY REQUIREMENTS OTHER THAN SHOWN.
3. ** INSTALLER MUST PROVIDE TRAP FOR PROPER INSTALLATION.
- 4 REFER TO 5874 SERIES OPERATION AND MAINTENANCE MANUAL FOR PUSH BUTTON AND VALVE INSTALLATION/MAINTENANCE INSTRUCTIONS.

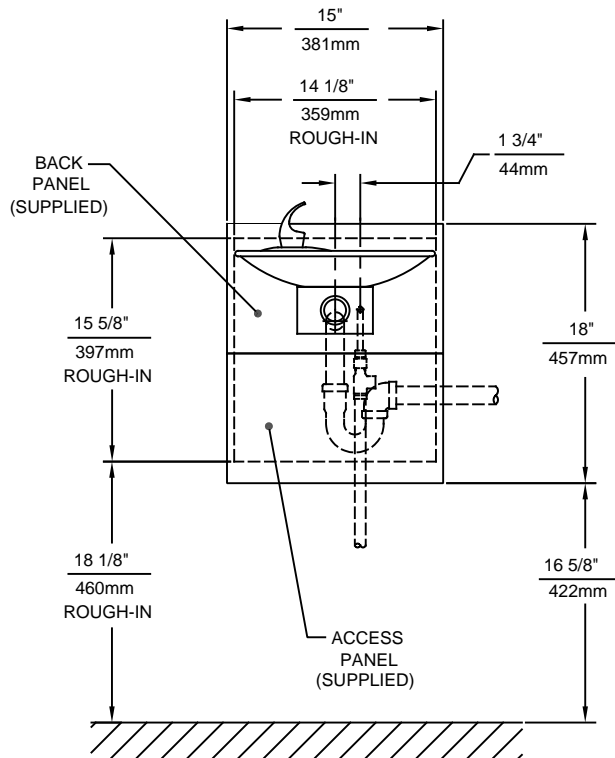

REMOVE VALVE FROM PUSH BUTTON TO INSTALL WASTE ELBOW ONTO BOWL. AFTER WASTE ELBOW IS INSTALLED, REINSTALL VALVE & ADJUST FLOW

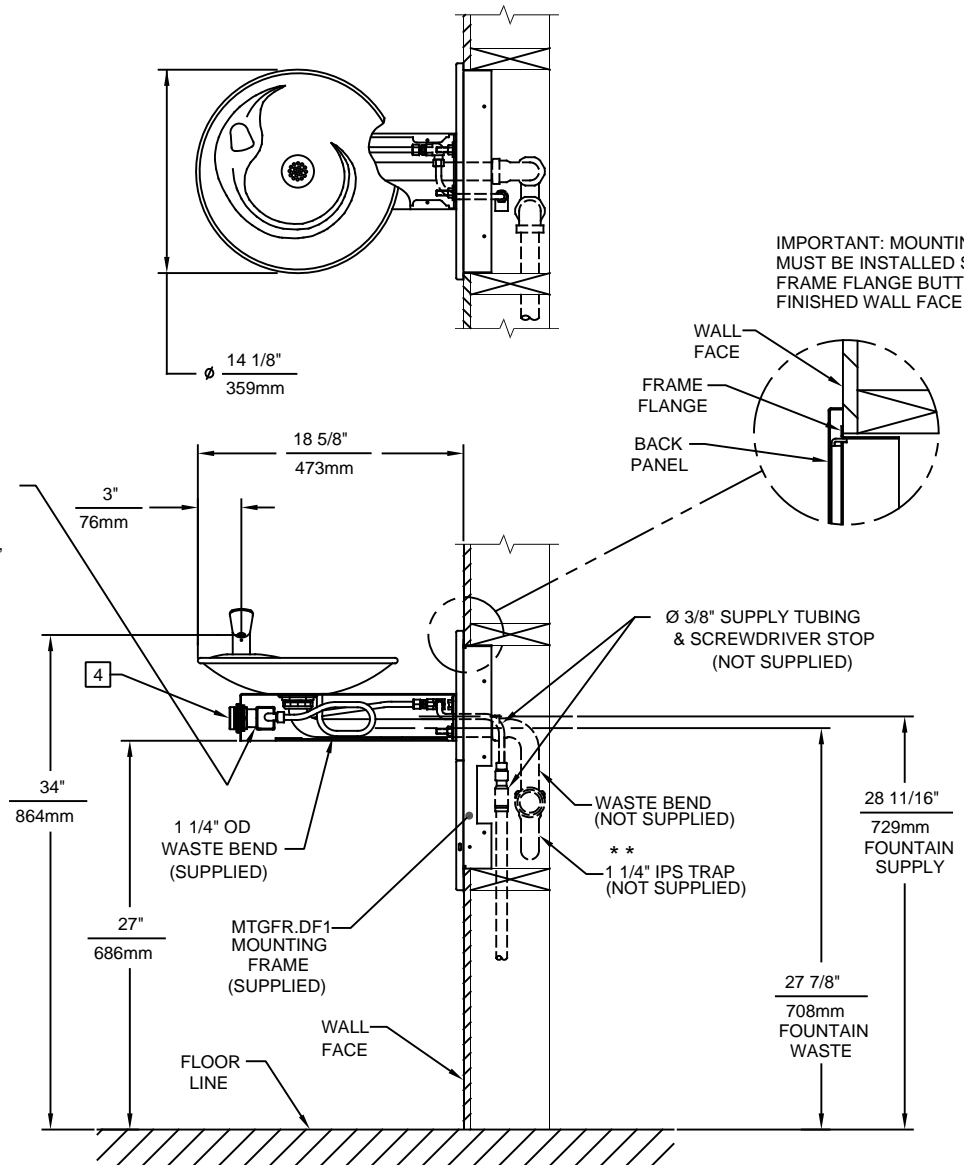

IMPORTANT: MOUNTING FRAME MUST BE INSTALLED SO THAT FRAME FLANGE BUTTS AGAINST FINISHED WALL FACE.

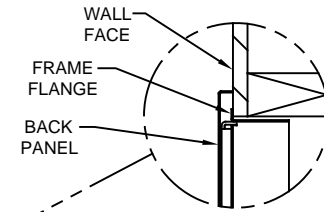

1455 KLEPPE LANE
SPARKS, NEVADA 89431
(775) 359-4712 FAX (775) 359-7424
E-MAIL: HAWS@HAWS.CO.COM
WEBSITE: WWW.HAWS.CO.COM

| | | |
|-------------------------|------------------|----------------------------|
| ECN NO. REVISED PER BY: | MODEL(S) | PART NUMBER |
| 5124 JPN | 1001MS/1001HPSMS | 0002076510.D |
| DRAWN: PM | DATE: 08/02/99 | CHKD.: VWC |
| APPROVED: FV | DATE: 07/06/17 | REVISION |
| | SCALE: 1:14 | DRAWING TYPE: INSTALLATION |
| | | SIZE: A SHEET 1 OF 1 |