



model 1109
Barrier-Free Wall Mount Fountain

FEATURES & BENEFITS

CONSTRUCTION

Unit is made of 18 gauge Type 304 stainless steel with a satin finish that resists stains and corrosion, and has soft, rounded corners. Unit features stainless steel satin finish back panel, vandal-resistant bottom plate, and 1-1/4" integral trap.

QUALITY CONTROL

Pre-built fountain is pressure tested to ensure no leaks and proper functionality.

BUBBLER HEAD

Polished chrome-plated brass bubbler head with integral basin shank for added strength. Shielded, angled stream opening provides a steady, sanitary source of drinking water at .45 gpm.

DRINKING FOUNTAIN VALVE

The push-button activated valve offers the only all stainless steel valve body that is machined out of solid bar stock, is fully serviceable through the front of the push button assembly offering access to the water control cartridge and integral water supply strainer, and with front access to the water stream height adjustment for easy maintenance without having to remove the valve. Operating pressure range of 30 to 90 psi (2.1 to 6.2 bar).

INTEGRATED TRAP

All cast brass 1-1/4" NPT adjustable trap completely concealed inside bottom plate for easy installation and access.

FOUNTAIN PUSH BUTTON

All chrome plated brass push button resists vandalism by allowing it to spin without unscrewing.



SPECIFICATIONS

Model 1109 barrier-free wall mounted drinking fountain shall include an 18 gauge Type 304 Stainless Steel satin finish basin, push-button operated stainless steel valve with front accessible cartridge, in-line strainer and flow adjustment, 100% lead-free waterways, polished chrome-plated brass vandal-resistant bubbler head, polished chrome-plated brass vandal-resistant waste strainer, vandal-resistant stainless bottom plate, and 1-1/4" NPT all cast-brass trap.

APPLICATIONS

Perfect for either public or private indoor/outdoor settings, Model 1109 is a great fit in areas where aesthetics are important to the overall appeal of the architecture. Beautiful satin finish helps to maintain the fountains overall appeal. Specifically, this type of wall mounted drinking fountain may be placed in settings such as: schools and other locations in and around office buildings where the temperature remains above freezing. Model meets all current Federal Regulations for the disabled including those in the Americans with Disabilities Act. Haws manufactures drinking fountains and electric water coolers to be lead-free by all known definitions including NSF/ANSI Standard 61, Section 9, NSF/ANSI 372, California Proposition 65, and the Federal Safe Drinking Water Act. Product is compliant to California Health and Safety Code 116875 (AB 1953-2006).

OPTIONS

- Remote Drinking Fountain Water chiller: Model HCR8, 8 gph (30.3 L) remote water chiller provides instantaneous cooling to meet a continuous demand for chilled water.
- Bottle Filler: Model 1920, bottle filler can be a stand-alone station, or mounted above Haws 1001, 1011, 1107L, 1109, 1117L, and 1119 series drinking fountain models.
- Mounting Plate: Model 6700 universal mounting plate for most wall mounted fountains. Priced Separately.
- Support Frame: Model 6800 universal in-wall mounting support for use with most fountains.

For more information, visit www.hawsco.com or call (888) 640-4297.



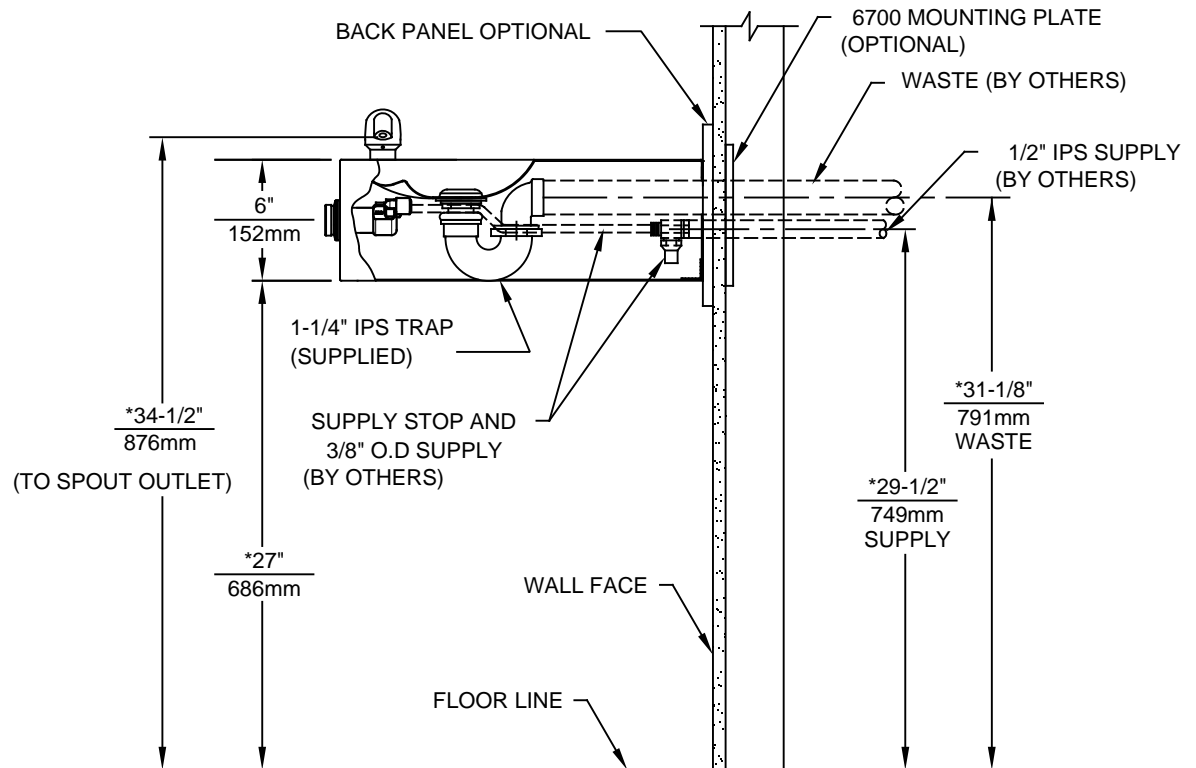
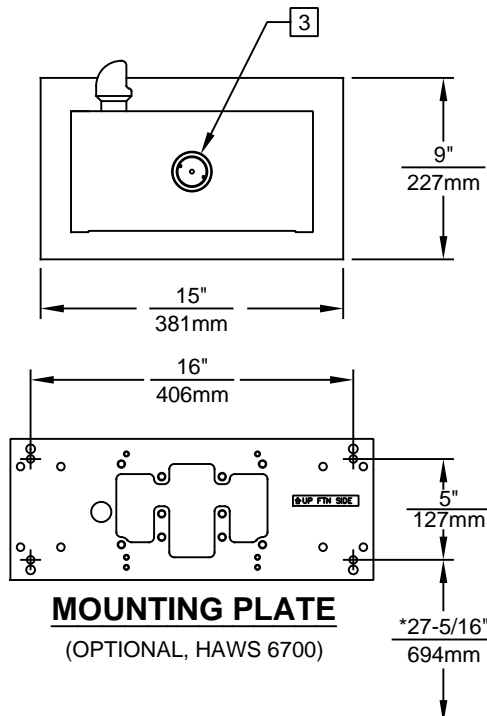
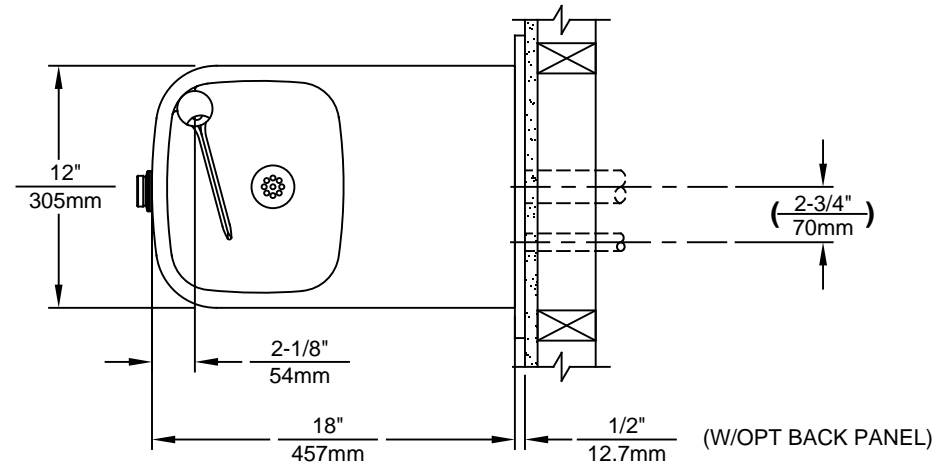
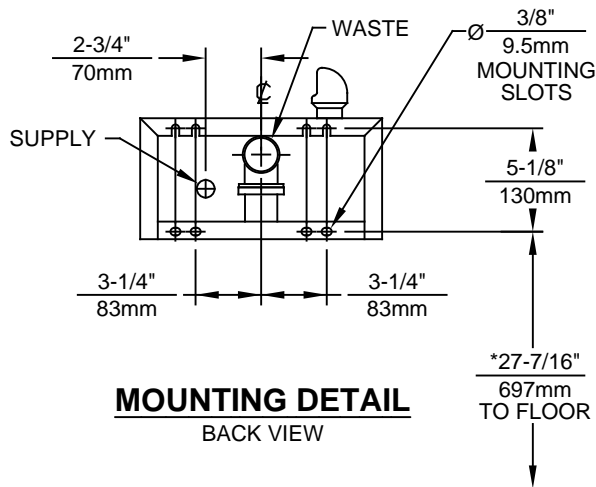

NOTES:

1. HOLD ROUGH-IN DIMENSIONS $\pm 1/4"$ (6.4mm).
2. WHEN INSTALLING THIS UNIT LOCAL, STATE OR FEDERAL CODES SHOULD BE ADHERED TO. FOR INSTALLATION HEIGHTS OTHER THAN SHOWN, DIMENSIONS MARKED (*) MUST BE ADJUSTED ACCORDINGLY.

3] REFER TO 5874 SERIES/VRK5874 OPERATION AND MAINTENANCE MANUAL FOR PUSH BUTTON AND VALVE INSTALLATION/MAINTENANCE INSTRUCTIONS.

		1455 KLEPPE LANE SPARKS, NEVADA 89431 (775) 359-4712 FAX (775) 359-7424 E-MAIL: HAWS@HAWSCO.COM WEBSITE: WWW.HAWSCO.COM	
		ECN NO. REVISED PER BY: MODEL(S) ECN: 5215 JP	1109
DRAWN: F. VASQUEZ DATE: 03/96 APPROVED: FV	DATE: 11/22/17	CHKD.: GC	REVISION 20
SCALE: NA		DRAWING TYPE: INSTALLATION	SIZE: A SHEET 1 OF 1