

ITEM	DESCRIPTION	PART #
1	BUTTON, PUSH, FLANGED, PCP W/ VALVE	5874PBF
2	VALVE REPAIR KIT	VRK5874
3	PUSH BUTTON ASSY	PBA6
4	BUBBLER HEAD ASSY, PCP	5703M
5	STRAINER, WASTE ASSY	6462
6	TRAP	0005982900
** 7	MOUNTING PLATE	6717
8	BOTTOM PLATE	PBM1107

** REQUIRED - SOLD SEPARATELY

NOTES:

- 1 5874PBF (ITEM 2) INCLUDES VRK5874 CARTRIDGE ASSEMBLY (ITEM 3) AND PBA6 FLANGED PUSH BUTTON (ITEM 4).
- 2 ENSURE TUBE IS DISCONNECTED FROM PUSH BUTTON VALVE BODY PRIOR TO REMOVAL. APPLY ONE DROP OF LOCTITE 222MS TO NOZZLE THREADS PRIOR TO FASTENING BACK ONTO BUBBLER HEAD. RE-ATTACH TUBE TO VALVE.

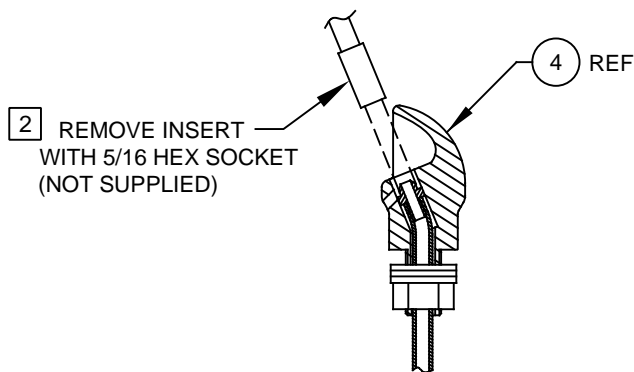
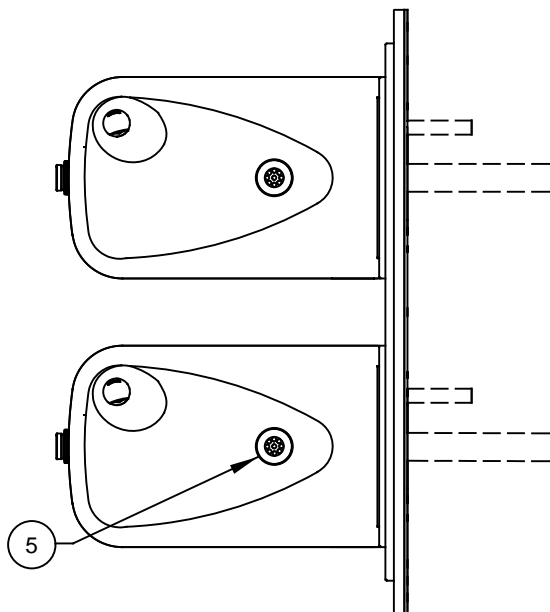

DETAIL A
ROTATED 90° INTO VIEW

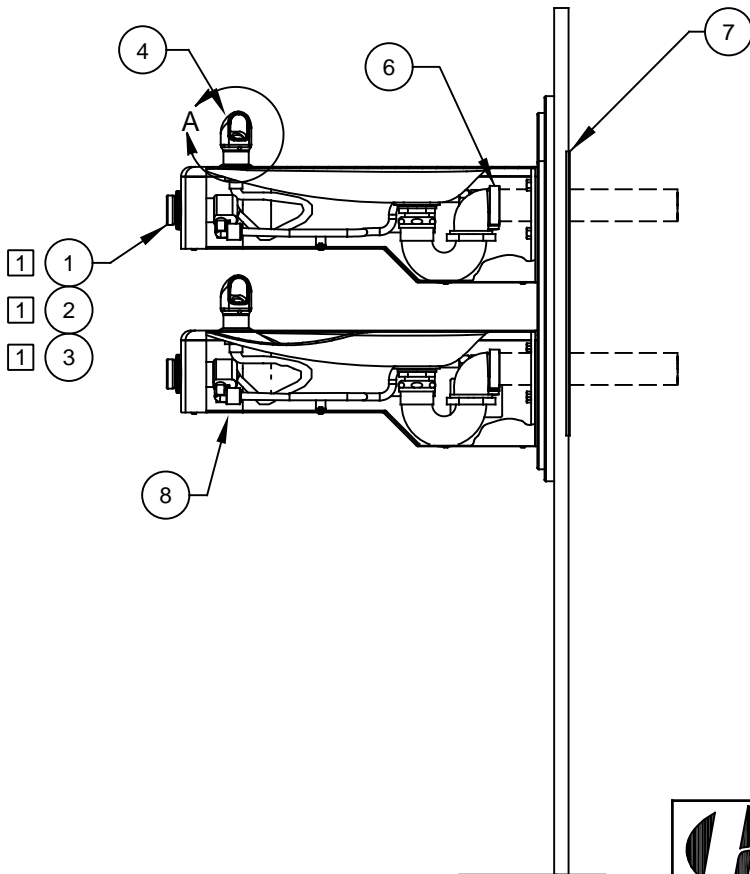

PARTS BREAKDOWN

		Haws [®]		1455 KLEPPE LANE SPARKS, NEVADA 89431 (775) 359-4712 FAX (775) 359-7424 E-MAIL: HAWS@HAWS.CO.COM WEBSITE: WWW.HAWS.CO.COM	
				ECN NO. REVISED PER BY ECN: 5527 FV	MODEL(S) 1117L
DRAWN C.FENNER	DATE 10/28/06	CHKD DP			
APPROVED FV	DATE 04/02/20	SCALE: 1:1	DRAWING TYPE: PARTS BREAKDOWN	SIZE: A	SHEET 1 OF 1

WHEN ORDERING PARTS PLEASE SPECIFY MODEL NUMBER.