

ITEM	DESCRIPTION	1117LN
1	BUTTON, PUSH, FLANGED, PCP W/ VALVE	5874PBF
2	VALVE REPAIR KIT	VRK5874
3	PUSH BUTTON ASSY	PBA6
4	BUBBLER HEAD ASSY, PCP	5703M
5	STRAINER, WASTE ASSY	6462
6	TRAP	0005982900
7	PLATE MOUNTING	6700.4
8	PLATE BOTTOM	PBM1107

NOTES:

- 1 5874PBF (ITEM 2) INCLUDES VRK5874 CARTRIDGE ASSEMBLY (ITEM 3) AND PBA6 FLANGED PUSH BUTTON (ITEM 4).
- 2 ENSURE TUBE IS DISCONNECTED FROM PUSH BUTTON VALVE BODY PRIOR TO REMOVAL. APPLY ONE DROP OF LOCTITE 222MS TO NOZZLE THREADS PRIOR TO FASTENING BACK ONTO BUBBLER HEAD. RE-ATTACH TUBE TO VALVE.

(OPTIONAL)

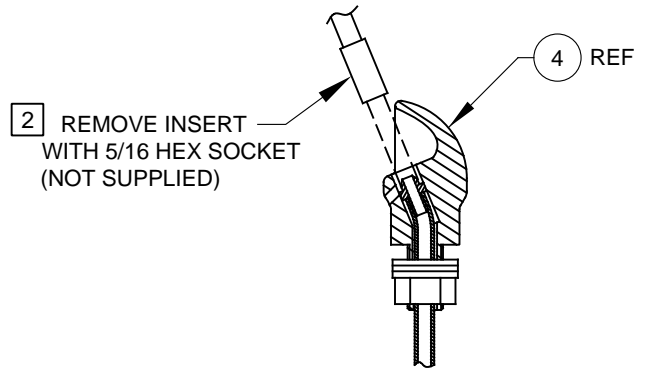
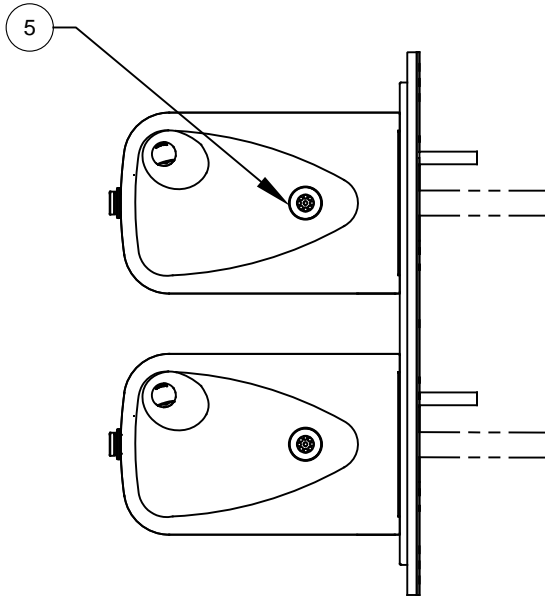

DETAIL A
ROTATED 90° INTO VIEW

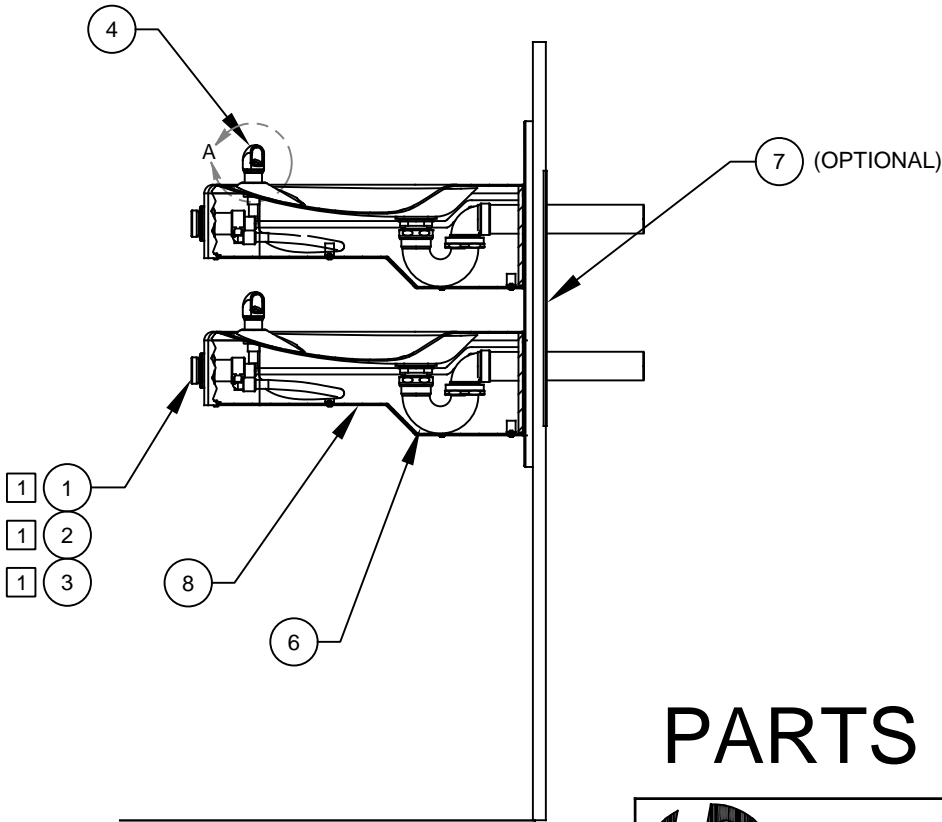

PARTS BREAKDOWN

		Haws [®]		1455 KLEPPE LANE SPARKS, NEVADA 89431 (775) 359-4712 FAX (775) 359-7424 E-MAIL: HAWS@HAWSCO.COM WEBSITE: WWW.HAWSCO.COM	
				ECN NO. 5221 DRAWN GC APPROVED FV	REVISED PER ECN: 5255 DATE 08/23/17 DATE 11/22/17
WHEN ORDERING PARTS PLEASE SPECIFY MODEL NUMBER.				SCALE: 1:1	DRAWING TYPE: PARTS BREAKDOWN