



model 1117LN

Barrier-Free Dual Wall Mount Fountain

FEATURES & BENEFITS

INTEGRATED TRAP

All cast brass 1-1/4" NPT adjustable traps completely concealed inside bottom plates for easy installation and lack of unwanted access.

BUBBLER HEAD

Polished chrome-plated brass bubbler head with integral basin shank for added strength. Shielded, angled stream opening provides a steady, sanitary source of drinking water at .45 gpm.

DRINKING FOUNTAIN VALVE

The push-button activated valve offers the only all stainless steel valve body that is machined out of solid bar stock, is fully serviceable through the front of the push button assembly offering access to the water control cartridge and integral water supply strainer, and with front access to the water stream height adjustment for easy maintenance without having to remove the valve. Operating pressure range of 30 to 90 psi (2.1 to 6.2 bar).

CUSTOM LOGO PANEL

Personalize your new or existing fountain or bottle filler where space permits with an optional customizable 10" high by 4.25" wide stainless steel panel. Virtually any company logo, event logo or graphic can be placed on this panel. Mounted with strong, moisture-resistant adhesive backing.

IN-WALL MOUNTING SYSTEM

Install with optional 6700.4 in-wall mounting plate which is 36" wide by 3/16" thick solid steel that spans three studs for a heavy-duty vandal-resistant rigid installation.

CONSTRUCTION

One-piece drinking fountains with low-profile design made of 14 gauge Type 304 stainless steel with 1/4" (.6 cm) thick stainless back plates welded in, and vandal-resistant stainless bottom plates. Satin finish resists stains and corrosion.



SPECIFICATIONS

Model 1117LN low profile Hi-Lo wall-mounted barrier-free drinking fountain shall include dual 14 gauge Type 304 stainless steel satin-finish basins with integral 1/4" (.6 cm) thick stainless steel mounting plates. Push-button operated stainless steel valves with front-accessible cartridge, in-line strainer and flow adjustment provide 100% lead free waterways, polished chrome-plated brass vandal-resistant bubbler heads, polished chrome-plated brass vandal-resistant waste strainers, vandal-resistant bottom plates, stainless steel satin finish back panel, and 1-1/4" NPT concealed all cast-brass traps.

APPLICATIONS

Perfect for either public or private indoor/outdoor settings, Model 1117LN is a great fit in areas where aesthetics are important to the overall appeal of the architecture. Beautiful satin finish helps to maintain the fountains overall appeal. Specifically, this type of wall mounted drinking fountain may be placed in settings such as: schools and other locations in and around office buildings where the temperature remains above freezing. Model meets all current Federal Regulations for the disabled including those in the Americans with Disabilities Act. Haws manufactures drinking fountains and electric water coolers to be lead-free by all known definitions including NSF/ANSI Standard 61, Section 9, NSF/ANSI 372, California Proposition 65, and the Federal Safe Drinking Water Act. Product is compliant to California Health and Safety Code 116875 (AB 1953-2006).

OPTIONS

- ❑ Custom Logo Panel: Model 6475, Hydration By Haws™ logo panel with customization options.
- ❑ Cane Detection, Floor Mounted: Model SK6, floor mounted cane detection for the Haws Hi-Lo drinking fountains.
- ❑ Remote Drinking Fountain Water chiller: Model HCR8, 8 gph (30.3 L) remote water chiller provides instantaneous cooling to meet a continuous demand for chilled water.
- ❑ Bottle Filler: Model 1920 stand-alone bottle filling station, or mounted above Haws 1001, 1011, 1107L, 1109, 1117L, and 1119 series drinking fountain models.

For more information, visit www.hawsc.com or call (888) 640-4297.



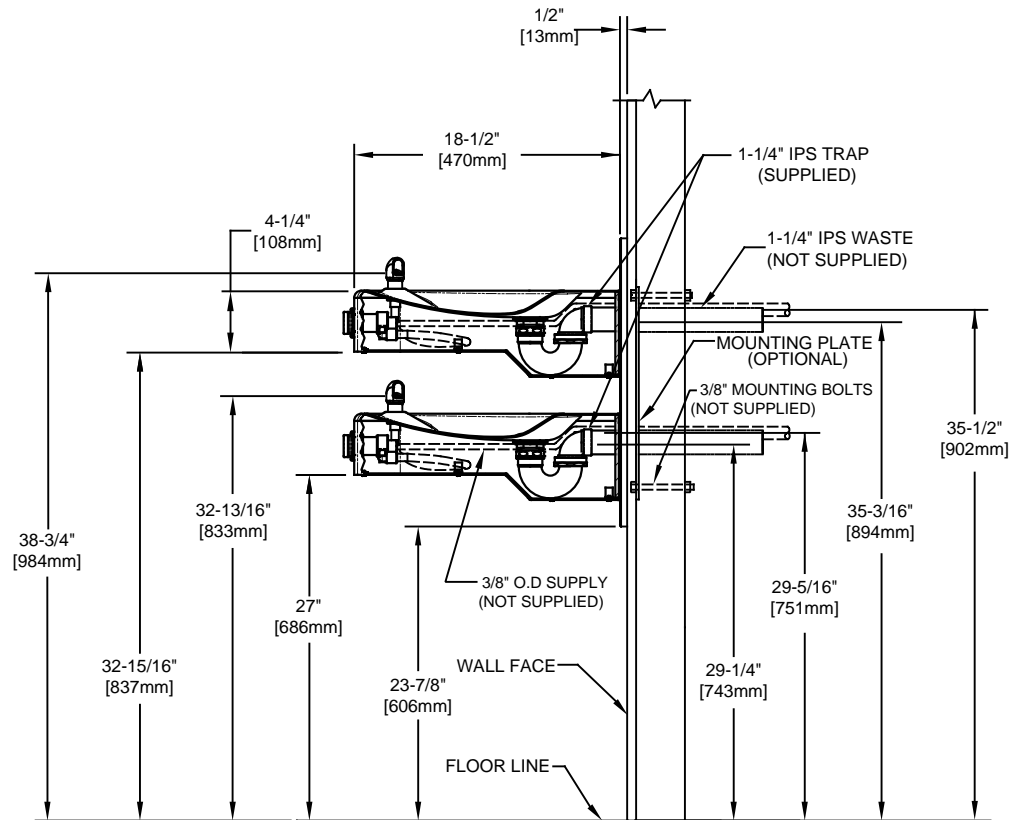
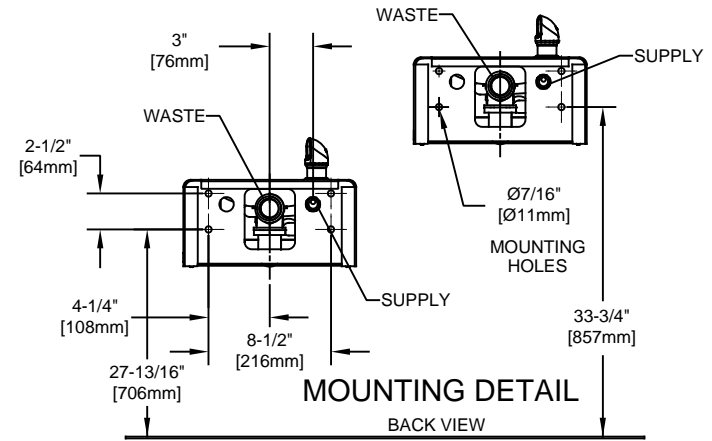
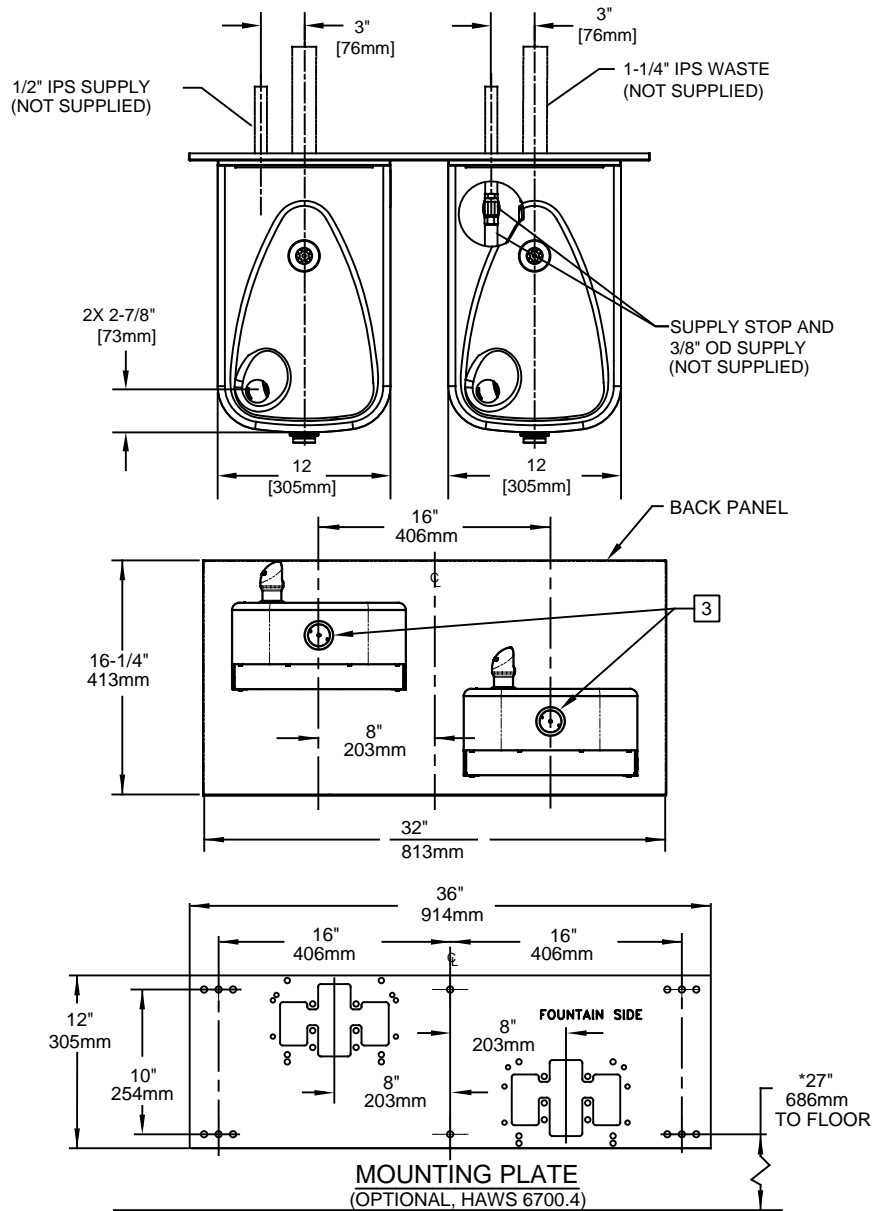

NOTES:

- HOLD ROUGH-IN DIMENSIONS ± 1/8" (3.2mm).
- WHEN INSTALLING THIS UNIT, LOCAL, STATE, OR FEDERAL CODES SHOULD BE ADHERED TO. FOR INSTALLATION HEIGHTS OTHER THAN SHOWN, DIMENSIONS MARKED (*) MUST BE ADJUSTED ACCORDINGLY.
- REFER TO 5874SS/VRK5874 OPERATION AND MAINTENANCE MANUAL FOR PUSH BUTTON AND VALVE INSTALLATION/MAINTENANCE INSTRUCTIONS.

1455 KLEPPE LANE
SPARKS, NEVADA 89431
(775) 359-4712 FAX (775) 359-7424
E-MAIL: HAWS@HAWSCO.COM
WEBSITE: WWW.HAWSCO.COM

ECN NO. 5221	REVISED PER ECN: 5255	BY: JP	MODEL(S) 1117LN	PART NUMBER 058000675.D
DRAWN: GC	DATE: 08/23/17	CHKD.: GC		REVISION 2
APPROVED: FV	DATE: 11/22/17		SCALE: 1:14	DRAWING TYPE: INSTALLATION
			SIZE: A	SHEET 1 OF 1