



# model 1311

## Barrier-Free Enameled Iron Wall Mount Fountain

### FEATURES & BENEFITS

#### CONSTRUCTION

Heavy-duty cast iron bowl with a glossy white enamel finish is designed for the toughest of applications, and at the same time is gentle to all users with its soft rounded corners. Unit also ships with vandal-resistant bottom plates to provide added peace of mind.

#### BUBBLER HEAD

Polished chrome-plated brass bubbler head with integral basin shank for added strength. Shielded, angled stream opening provides a steady, sanitary source of drinking water at .45 gpm.

#### DRINKING FOUNTAIN VALVE

The push-button activated valve offers the only all stainless steel valve body that is machined out of solid bar stock, is fully serviceable through the front of the push button assembly offering access to the water control cartridge and integral water supply strainer, and with front access to the water stream height adjustment for easy maintenance without having to remove the valve. Operating pressure range of 30 to 90 psi (2.1 to 6.2 bar).

#### INTEGRATED TRAP

All cast brass 1-1/4" NPT adjustable trap completely concealed inside bottom plate for easy installation and access.

#### FOUNTAIN PUSH BUTTON

All chrome plated brass push button resists vandalism by allowing it to spin without unscrewing.



### SPECIFICATIONS

Model 1311 wall-mounted barrier-free drinking fountain shall include a white enameled-iron basin, push-button operated stainless steel valve with front-accessible cartridge and flow adjustment, adult or child ADA mounting heights, 100% lead-free waterways, polished chrome-plated brass vandal-resistant bubbler head, polished chrome-plated brass vandal-resistant waste strainer, vandal-resistant bottom plate, and chrome-plated 1-1/4" NPT trap.

### OPTIONS

- ❑ Remote Drinking Fountain Water chiller: Model HCR8, 8 gph (30.3 L) remote water chiller provides instantaneous cooling to meet a continuous demand for chilled water.
- ❑ Bottle filler: Model 1920W, bottle filler can be a stand-alone station, or mounted above Haws 1311 and 1501 and other drinking fountain models.
- ❑ Mounting Plate: Model 6700 universal mounting plate for most wall mounted fountains. Priced Separately.
- ❑ Support Frame: Model 6800 universal in-wall mounting support for use with most fountains.

For more information, visit [www.hawsc.com](http://www.hawsc.com) or call (888) 640-4297.

### APPLICATIONS

Perfect for either public or private settings, our gleaming white enameled iron series is one of the sturdiest wall mounted fountains Haws produces. This series is precisely mounted, making it a nice addition to any surrounding. Elegant gloss finish and color consistency throughout the enameled iron maintain the fountains overall appeal so it always remains looking as new as it did when it was installed. Specifically, this type of wall mounted drinking fountain may be placed in settings such as: parks, schools, and other indoor/outdoor environments where the temperature remains above freezing. Model meets all current Federal Regulations for the disabled including those in the Americans with Disabilities Act. Haws manufactures drinking fountains and electric water coolers to be lead-free by all known definitions including NSF/ANSI Standard 61, Section 9, NSF/ANSI 372, California Proposition 65, and the Federal Safe Drinking Water Act. Product is compliant to California Health and Safety Code 116875 (AB 1953-2006).



1. HOLD ROUGH-IN DIMENSIONS  $\pm 1/4"$  (6.4MM).
2. WHEN INSTALLING THIS UNIT, LOCAL, STATE, OR FEDERAL CODES SHOULD BE ADHERED TO. FOR INSTALLATION HEIGHTS OTHER THAN SHOWN, DIMENSIONS MARKED (\*) MUST BE ADJUSTED ACCORDINGLY.
- 3 REFER TO 5874 SERIES VALVE OPERATION AND MAINTENANCE MANUAL FOR PUSH BUTTON AND VALVE INSTALLATION/MAINTENANCE INSTRUCTIONS.

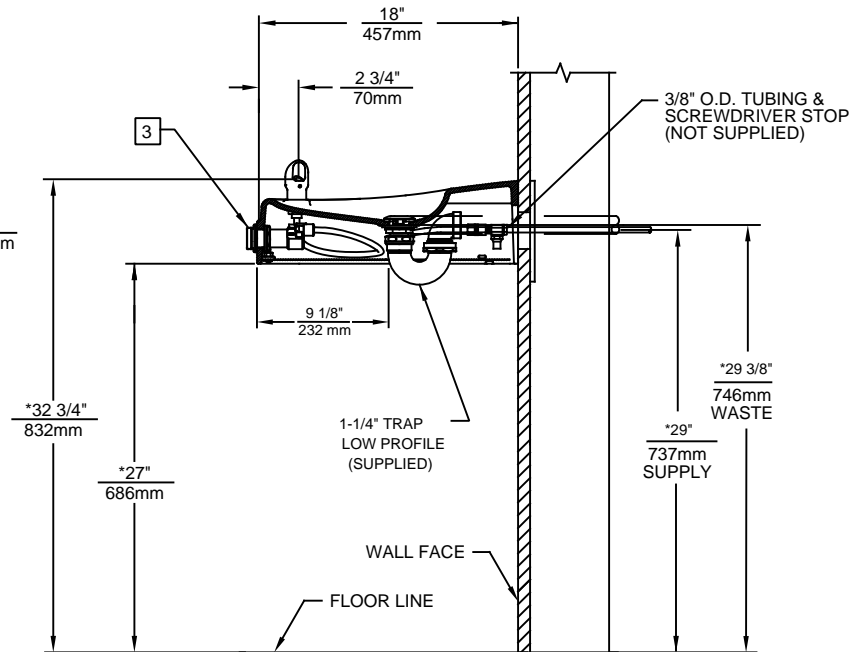
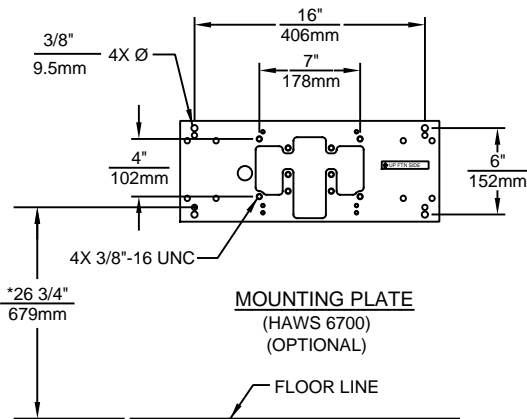
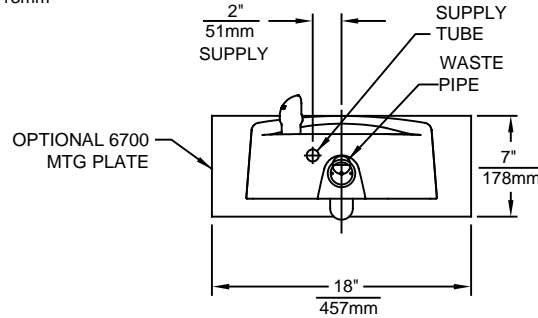
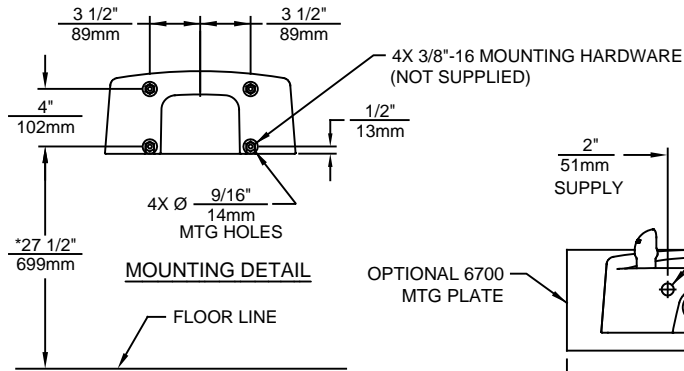
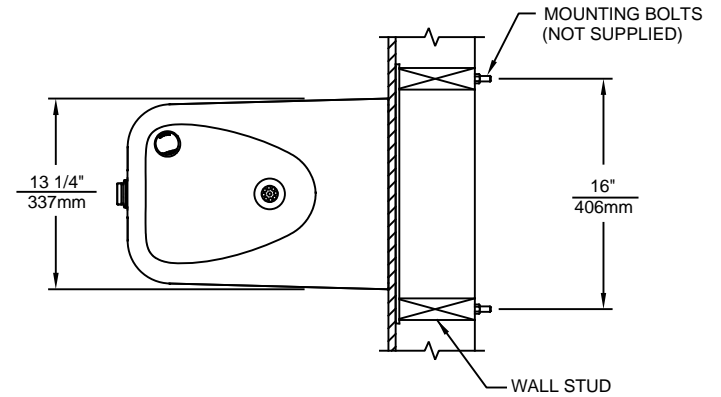

1455 KLEPPE LANE  
 SPARKS, NEVADA 89431  
 (775) 359-4712 FAX (775) 359-7424  
 E-MAIL: HAWS@HAWSCO.COM  
 WEBSITE: WWW.HAWSCO.COM

ECN NO. 5010	REVISED PER ECN: 5258	BY: JP	MODEL(S)	PART NUMBER
DRAWN: HM	DATE: 08/25/15	CHKD.: GC	1311	051000046.D
APPROVED: FV	DATE: 11/23/17		SCALE: 1:14	REVISION 4
			DRAWING TYPE: INSTALLATION	SIZE: A SHEET 1 OF 1