



model 1501

Barrier-Free Enameled Iron Wall Mount Fountain

FEATURES & BENEFITS

CONSTRUCTION

Heavy-duty cast iron bowl with a glossy white enamel finish is designed for the toughest of applications, and at the same time is gentle to all users with its soft rounded corners. Unit also ships with vandal-resistant bottom plates to provide added peace of mind.

INTEGRATED TRAP

All cast brass 1-1/4" NPT adjustable traps completely concealed inside bottom plates for easy installation and lack of unwanted access.

BARRIER-FREE

Barrier-free capabilities combined with its ease of use allows for a number of installation location possibilities.

MOUNTING

3/16" (.47 cm) steel mounting plate (sold separately) with supplied mounting hardware for a solid unit base allows for easy installation to a framed wall.

BUBBLER HEAD

Polished chrome-plated brass bubbler head with integral basin shank for added strength. Shielded, angled stream opening provides a steady, sanitary source of drinking water at .45 gpm.

DRINKING FOUNTAIN VALVE

The push-button activated valve offers the only all stainless steel valve body that is machined out of solid bar stock, is fully serviceable through the front of the push button assembly offering access to the water control cartridge and integral water supply strainer, and with front access to the water stream height adjustment for easy maintenance without having to remove the valve. Operating pressure range of 30 to 90 psi (2.1 to 6.2 bar).

FOUNTAIN PUSH BUTTON

All chrome plated brass push button resists vandalism by allowing it to spin without unscrewing.



SPECIFICATIONS

Model 1501 Hi-Lo wall-mounted barrier-free drinking fountain shall include dual white enameled-iron basins, push-button operated stainless steel valves with front-accessible cartridge and flow adjustment, 100% lead-free waterways, polished chrome-plated brass vandal-resistant bubbler heads, polished chrome-plated brass vandal-resistant waste strainers, vandal-resistant bottom plates, white powder-coated stainless steel back panel and 1-1/4" NPT traps.

REQUIRES MODEL 6715 PRICED SEPARATELY

APPLICATIONS

Perfect for either public or private settings, our gleaming white enameled iron series is one of the sturdiest wall mounted fountains Haws produces. This unit is the perfect fit for high traffic areas where there is a greater need for multiple drinking stations. Elegant gloss finish and color consistency throughout the enameled iron maintain the fountain's overall appeal so it always remains looking as new as it did when it was installed. Specifically, this type of wall mounted drinking fountain may be placed in settings such as: parks, schools, and other indoor/outdoor environments where the temperature remains above freezing. Model meets all current Federal Regulations for the disabled including those in the Americans with Disabilities Act. Haws manufactures drinking fountains and electric water coolers to be lead-free by all known definitions including NSF/ANSI Standard 61, Section 9, NSF/ANSI 372, California Proposition 65, and the Federal Safe Drinking Water Act. Product is compliant to California Health and Safety Code 116875 (AB 1953-2006).

OPTIONS

- Cane Detection, Floor Mounted: Model SK6, floor mounted cane detection for the Haws Hi-Lo drinking fountains.
- Remote Drinking Fountain Water chiller: Model HCR8, 8 gph (30.3 L) remote water chiller provides instantaneous cooling to meet a continuous demand for chilled water.
- Bottle Filler: Model 1920, bottle filler can be a stand-alone station, or mounted above Haws 1001, 1011, 1107L, 1109, 1117L, and 1119 series drinking fountain models.
- Support Frame: Model 6800 universal in-wall mounting support for use with most fountains.

For more information, visit www.hawsc.com or call (888) 640-4297.



NOTES:

- 1 1 1/4" DIM TO SLOTTED OPENING ON THE MOUNTING PLATE MUST BE ON THE TOP LEFT HAND SIDE WHEN INSTALLED.
- 2 1/2" DIM TO SLOTTED OPENING ON THE BACKPANEL MUST BE ON TOP LEFT HAND SIDE WHEN INSTALLED.
3. HOLD ROUGH-IN DIMENSIONS ± 1/4" (6.4MM).
4. WHEN INSTALLING THIS UNIT, LOCAL, STATE, OR FEDERAL CODES SHOULD BE ADHERED TO. FOR INSTALLATION HEIGHTS OTHER THAN SHOWN, DIMENSIONS MARKED (*) MUST BE ADJUSTED ACCORDINGLY.
- 5 REFER TO 5874 SERIES OPERATION AND MAINTENANCE MANUAL FOR PUSH BUTTON AND VALVE INSTALLATION/MAINTENANCE INSTRUCTIONS.

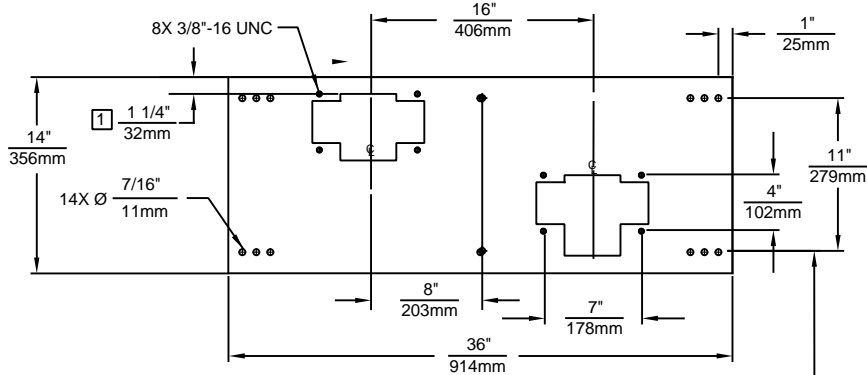

6715 MOUNTING PLATE
MUST BE INSTALLED BEFORE FINISH WORK.
THIS PLATE IS A STANDARD ITEM ON MODEL 1501ADA.

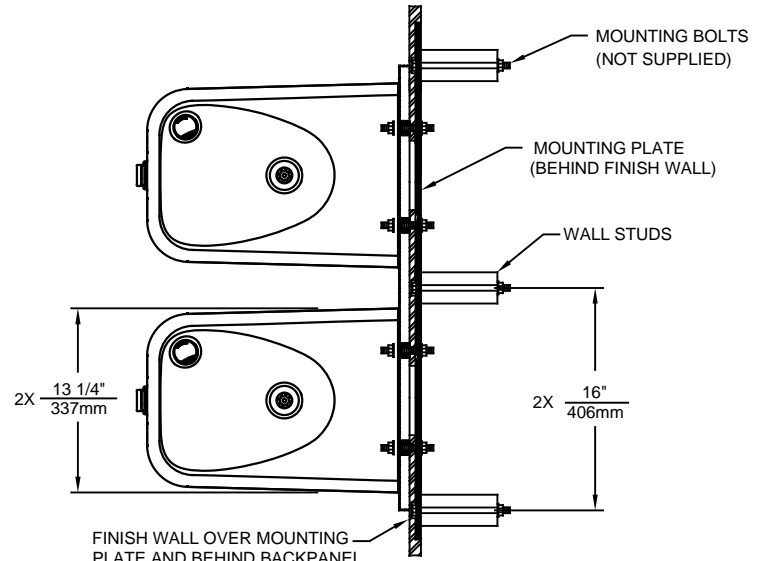
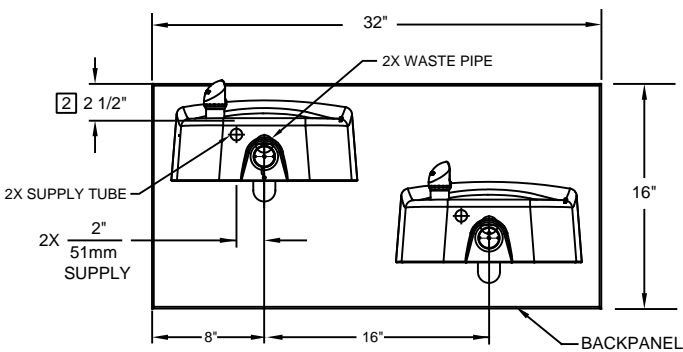

FINISH WALL OVER MOUNTING PLATE AND BEHIND BACKPANEL. BE CAREFUL THAT FINISHED WALL EXTENDS WITHIN THE HAWS BACKPANEL.

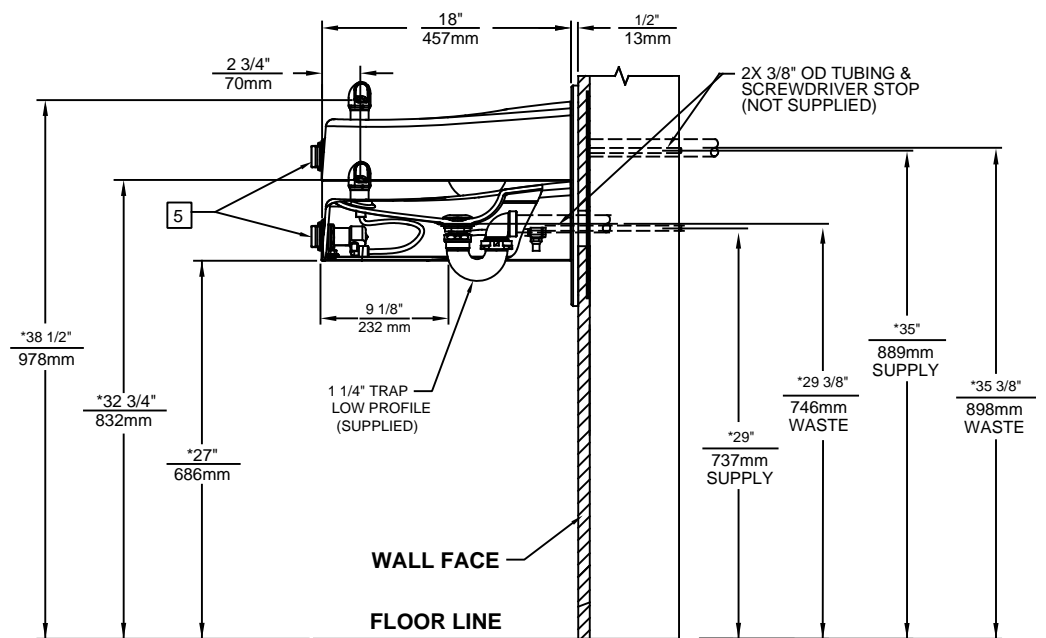



1455 KLEPPE LANE
SPARKS, NEVADA 89431
(775) 359-4712 FAX (775) 359-7424
E-MAIL: HAWS@HAWSCO.COM
WEBSITE: WWW.HAWSCO.COM

ECN NO. 5010	REVISED PER ECN: 5218	BY: JP	MODEL(S)	1501	PART NUMBER
DRAWN: HM	DATE: 08/25/15	CHKD.: GC			051000047.D
APPROVED: FV	DATE: 11/23/17		SCALE: 1:1	DRAWING TYPE: INSTALLATION	REVISION 4
			SIZE: A	SHEET 1 OF 1	