

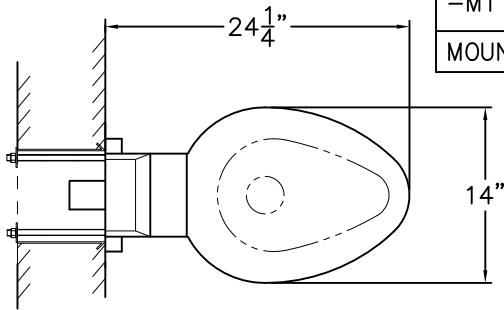

REFERENCE DRAWINGS		
-SW WALL SLEEVE /	-W WALL SUPPLY	9925-230-001
-MT METAL TEMPLATE	-T TOP SUPPLY	9925-231-001
MOUNTING HARDWARE		9957-900-001



TOP VIEW

FOR -ADA MODELS -FLUSH VALVE MUST BE HYDRAULICALLY ACTUATED OR SUPPLIED WITH A SPECIAL HANDLE. MAX. CONTROL HEIGHT IS 36" ABOVE FINISHED FLOOR. CONTROLS MUST BE LOCATED ON OPEN SIDE OF TOILET.

NOTE: REFER TO A.D.A. ACCESSIBILITY GUIDELINES FOR COMPLETE INSTALLATION REQUIREMENTS.

NOTE: FOR UNITS WITH SUFFIX OPTION -ADA, ALL VERTICAL DIMENSIONS INDICATED * WILL INCREASE PROPORTIONALLY WITH ADA SEAT HEIGHT.

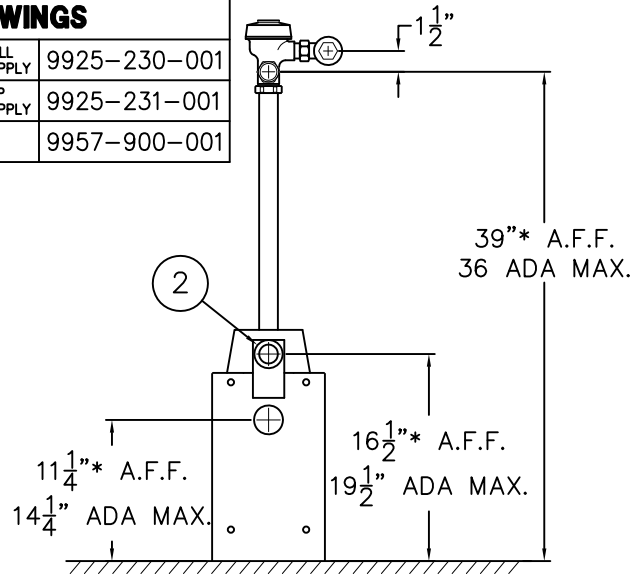

(-W) WALL SUPPLY REAR VIEW

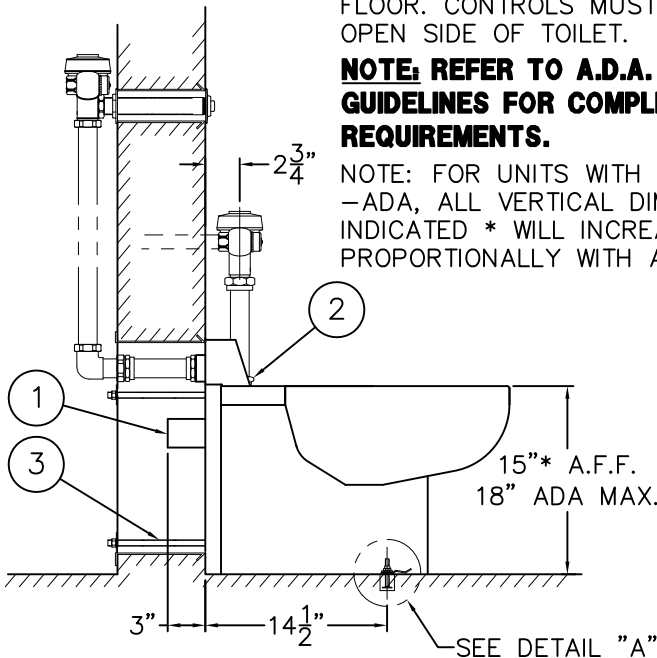

SIDE VIEW

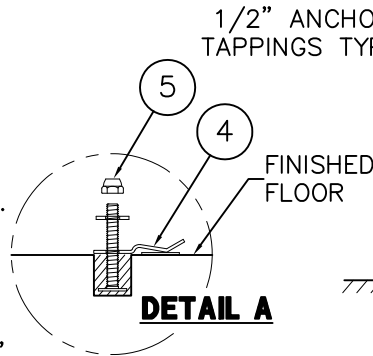

DETAIL A

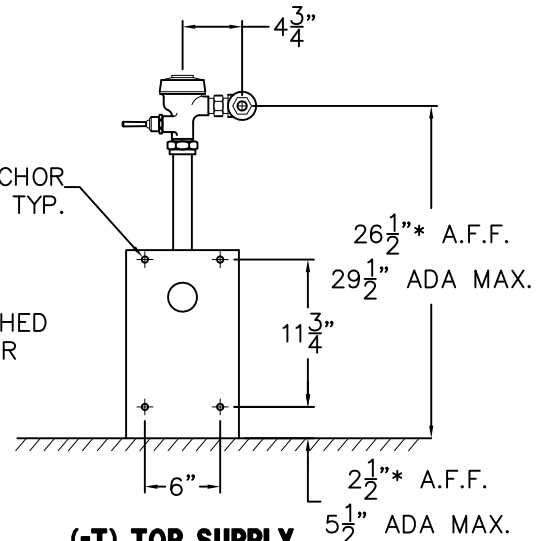

(-T) TOP SUPPLY REAR VIEW

INSTALLATION INSTRUCTIONS:

- A- SEE REFERENCE DRAWING BOX FOR WALL SLEEVE INSTALLATION INSTRUCTIONS (SUFFIX OPTION -SW).
- B- ROUGH-IN PLUMBING FOR THE FOLLOWING CONNECTIONS:
 - TOILET WALL WASTE OUTLET 2-3/8" O.D. PLAIN END ①.
 - SUFFIX OPTION -W03 3" O.D. PLAIN END WASTE ①.
 - FLUSHING INLET CONNECTION 1-1/2" NPT ②.
- C- INSTALL 1/2"-13 ALL THREAD STUDS ③ INTO ANCHOR TAPPINGS AT REAR OF FIXTURE. STUDS MUST HAVE A MINIMUM 1/2" ENGAGEMENT.

- D- ATTACH CONCEALED FLOOR ANCHORS ④ WITH T-BOLT ASSEMBLY ⑤ PROVIDED. SEE DETAIL "A".
- E- PLACE TOILET UP AGAINST CELL WALL, SLIDING THE STUDS THROUGH WALL SLEEVE OPENINGS AND ENGAGING WITH CONCEALED FLOOR ANCHORS ④.
- F- PLACE WASHERS AND NUTS ONTO STUDS ③; TIGHTEN TO 60FT/LBS.
- G- FLUSH SUPPLY LINE. MAKE-UP WASTE CONNECTION AND MOUNT FLUSH VALVE PER MANUFACTURERS' RECOMMENDATIONS.

ACORN ENGINEERING COMPANY P.O. BOX 3527 Industry, CA 91744 15125 Proctor Ave Industry, CA 91746 (626) 336-4561 FAX (626) 961-2200	TITLE BLOWOUT JET TOILET - ON FLOOR - CAT. #1685 / 1685-ADA -W/T	
	MANUFACTURE DATE OCT. 17, 1997 TO PRESENT	DATE ISSUED 8/18/97 DATE REVISED 04/04/13



BOTH VIEWS ARE FROM CELL SIDE
 SHADED AREAS ARE REQUIRED WALL OPENINGS

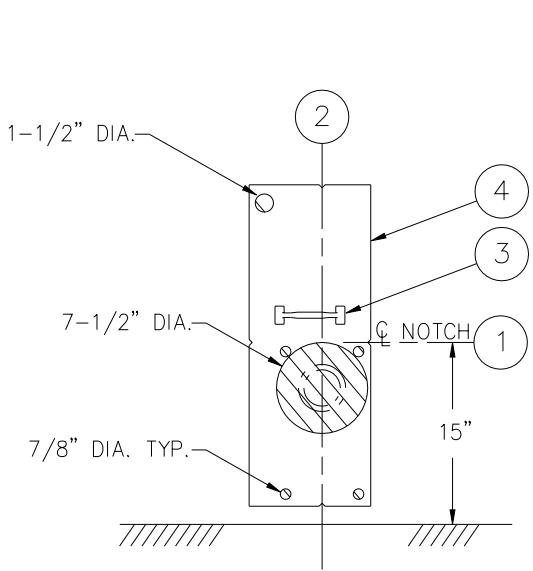

METAL TEMPLATE (-MT)

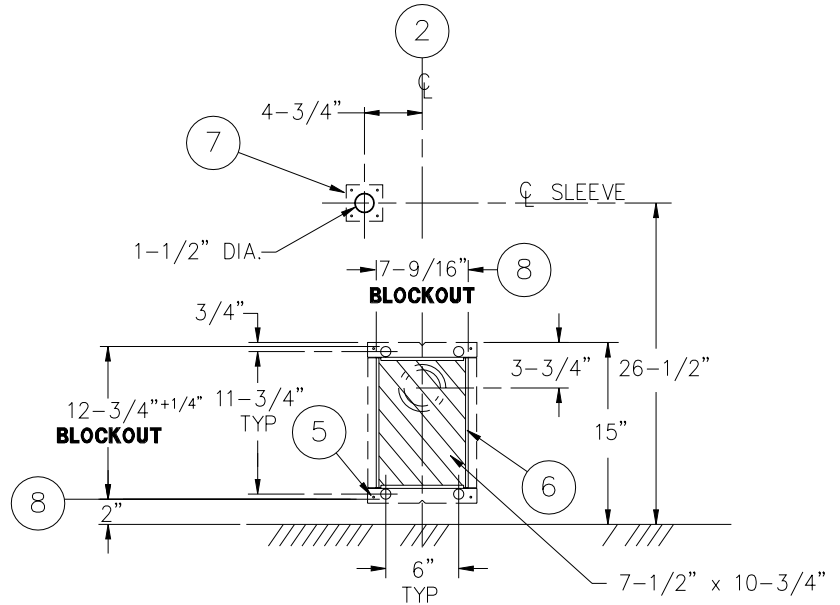

WALL SLEEVE (-SW)

NOTE: FOR SUFFIX OPTION -HC OR -A.D.A. UNITS:
 POSITION WALL SLEEVE WITH NOTCH FOR INTEGRAL SEAT AT HANDICAP DIMENSION -18" FOR A.D.A. MODELS. ALL VERTICAL DIMENSIONS CHANGE ACCORDING TO ADDITIONAL SEAT HEIGHT FOR HANDICAP. I.E. FOR 18" SEAT HEIGHT WASTE OUTLET BECOMES 14-1/4" FLUSHING INLET BECOMES 19-1/2".

NOTE:
 ON POURED WALL CONSTRUCTION, THE PUSHBUTTON SLEEVE, ITEM ⑦ IS CAPPED. THIS CAP MUST BE REMOVED FROM THE CHASE SIDE OF THE WALL, BEFORE INSTALLING F.V. PUSHBUTTON.

INSTALLATION INSTRUCTIONS

METAL TEMPLATES (-MT)

TEMPLATES ARE USED TO LAYOUT REQUIRED WALL OPENINGS FOR SUBSEQUENT FLAME CUTTING OR CORE DRILLING.

- A- STRIKE A HORIZONTAL CHALKLINE ① ON THE WALL 15" ABOVE FINISHED FLOOR. THIS WILL LOCATE CENTERLINE FOR HORIZONTAL NOTCHES ON TEMPLATE. (WHEN USING -HC OPTION SEE NOTE ABOVE)
- B- STRIKE A VERTICAL CHALKLINE ② ON THE WALL TO INDICATE CENTERLINE OF FIXTURE. THIS WILL LOCATE FOR VERTICAL NOTCHES ON TEMPLATE.
- C- USING HANDLE ③ ON TEMPLATE ④, PLACE TEMPLATE AGAINST THE WALL, LOCATING NOTCHES AT CHALKLINES. MARK FOR WALL OPENINGS.

WALL SLEEVES (-SW)

SLEEVES ARE INSTALLED IN FORMS (USING NAIL HOLES ⑤ PROVIDED) OR GROUTED INTO BLOCK WALLS, BECOMING A PERMANENT PART OF THE WALL.

NOTE: FOR POURED WALL CONSTRUCTION, TEMPORARY BRACING SHOULD BE INSTALLED WITHIN SLEEVE OPENING TO PREVENT DEFORMATION TO SLEEVE WHICH MAY OCCUR DURING POUR. DO NOT POUR CONCRETE DIRECTLY ON TOP OF WALL SLEEVE.

- A- INSTALL SLEEVE WITH FLANGE ⑥ ON CHASE SIDE OF WALL.
- B- TOP AND BOTTOM NOTCHES TO BE LOCATED AT VERTICAL CENTERLINE ② OF SLEEVE.
- C- TOP OF FLANGE TO BE LOCATED AT 15" ABOVE THE FINISHED CELL SIDE FLOOR (INTEGRAL TOILET SEAT HEIGHT).
- D- SEPARATE SLEEVE ⑦ FOR FLUSH VALVE PUSHBUTTON TO BE LOCATED 26-1/2" ABOVE FINISHED CELL SIDE FLOOR.
- E- WHEN SLEEVES ARE NOT AVAILABLE USE BLOCKOUT DIMENSIONS SHOWN ⑧.



ACORN ENGINEERING COMPANY
 P.O. BOX 3527 INDUSTRY, CA. 91744
 (626) 336-4561 FAX (626) 961-2200

TITLE SLEEVES AND TEMPLATES (CAT. #1685-T) (CAT. #1685-A.D.A.-T)

MANUFACTURE DATE

FEB 1975
TO PRESENT

DATE ISSUED

3-1-90

DATE REVISED

1/30/96

DRAWING NUMBER

9925-231-001

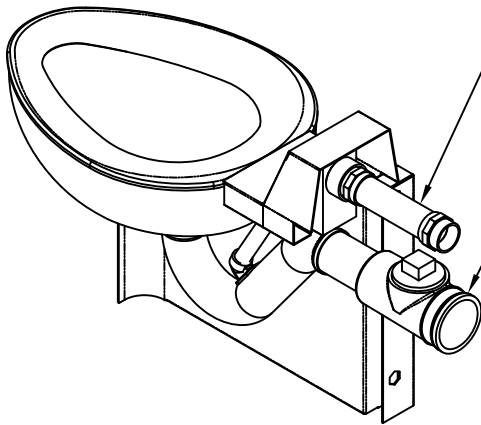

Optional -FVT Flush Valve Thru Wall Connection. Shown For Reference.

Optional -CO1 Waste Fitting. Shown For Reference.

REFERENCE DRAWING	
WASTE CONNECTION WITH CLEANOUT -CO1	9985-125-002

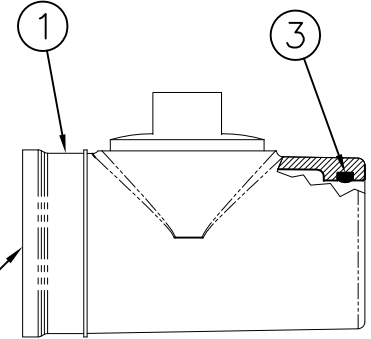

NOTE: Optional -CO1 Waste Fitting Available With 3" or 4" No-Hub

Scaled: X 2

Optional -FVT Flush Valve Thru Wall Connection Shown For Reference

Plain End Extends 3" Beyond Back Of Fixture. Optional Extended Waste Is Available -TWE

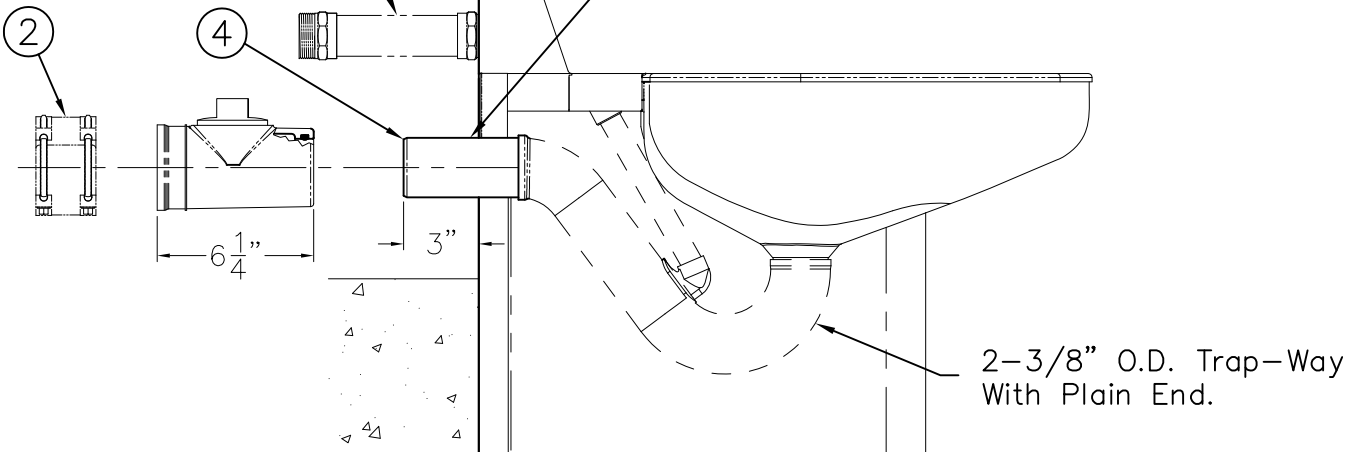

MODEL #1685 SHOWN FOR REFERENCE

INSTALLATION INSTRUCTIONS

A-INSERT O-RING ③ INTO GROOVE OF WASTE FITTING ①. LUBRICATE THE O-RING ③ WITH O-RING LUBRICANT.

B-INSTALL WASTE FITTING ① TO FIXTURE P-TRAP WASTE EXTENSION ④. ENGAGEMENT IS APPROXIMATELY 1-1/4". NOTE: TOILET WASTE

EXTENSION ④ IS 3" BEYOND BACK OF FIXTURE. LONGER WASTE EXTENSION IS AVAILABLE.

C-MAKE UP WASTE FITTING CONNECTION TO WASTE PIPING USING NO-HUB (BAND) CONNECTOR ② BY OTHERS.

ACORN ENGINEERING COMPANY
 P.O. BOX 3527 INDUSTRY, CA. 91744
 (626) 336-4561 FAX (626) 961-2200

TITLE NO-HUB WASTE CONNECTION WITH CLEANOUT -CO1		
MANUFACTURE DATE JULY 1975 PRESENT	DATE ISSUED 1/29/96	DRAWING NUMBER 9925-054-001
	DATE REVISED 11/08/13 D	



**MOUNTING
DETAIL
"A-A"**

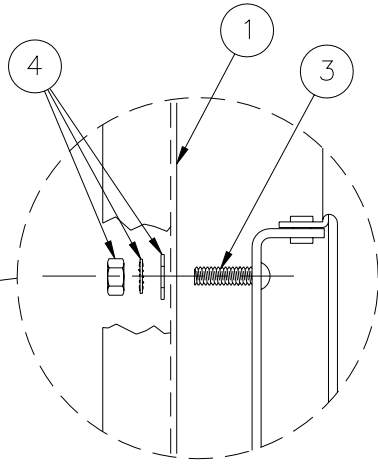

**MOUNTING
DETAIL
"B-B"**

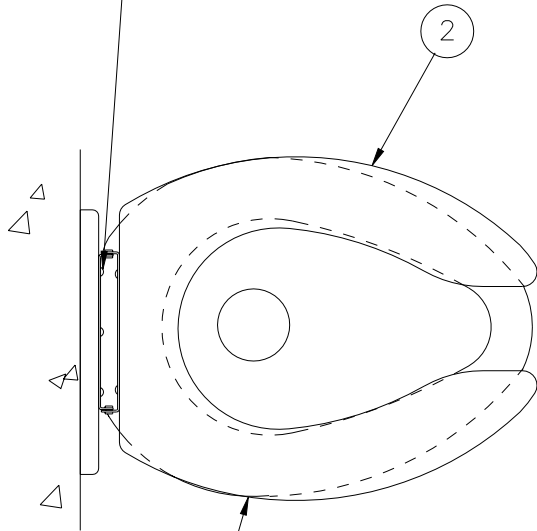
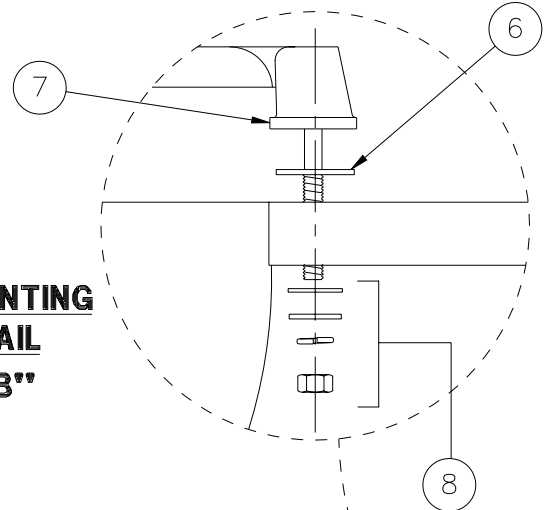

1679 TOILET
SHOWN FOR
REFERENCE
ONLY

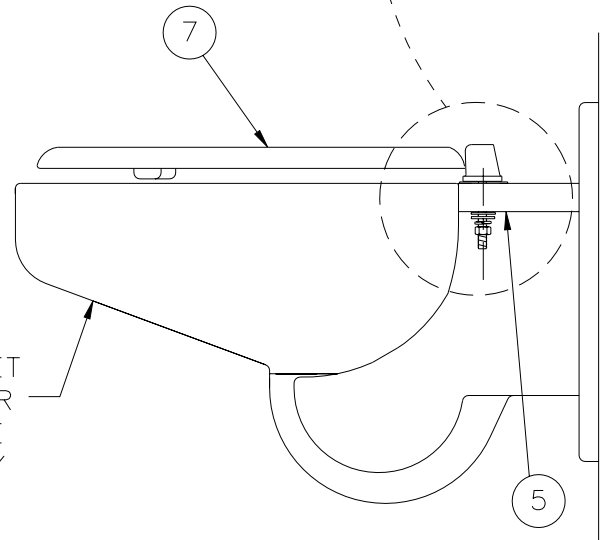

1675 TOILET
SHOWN FOR
REFERENCE
ONLY

**INSTALLATION INSTRUCTIONS-COMBY AND 1679 TOILET
PRIOR TO MOUNTING FIXTURE ON WALL:**

- A- LOCATE HINGED SEAT MOUNTING HOLES ON FIXTURE ①.
- B- POSITION HINGED SEAT ② AGAINST UNIT ① BY INSERTING SCREWS ③ INTO MOUNTING HOLES.
- C- ASSEMBLE NUT, WASHER AND LOCK-WASHER ④ AS SHOWN IN MOUNTING DETAIL "A-A".

**INSTALLATION INSTRUCTIONS-TOILETS
PRIOR TO MOUNTING FIXTURE ON WALL:**

- A- LOCATE HINGED SEAT MOUNTING HOLES IN FIXTURE ⑤.
- B- INSERT WASHERS ⑥ BETWEEN TOP OF TOILET AND HINGE SEAT ⑦.
- C- POSITION HINGED SEAT ⑦ ON TOP OF UNIT.
- D- ASSEMBLE HARDWARE ⑧ AS SHOWN IN MOUNTING DETAIL "B-B"



ACORN ENGINEERING COMPANY
P.O. BOX 3527 INDUSTRY, CA. 91744
(626) 336-4561 FAX (626) 961-2200

TITLE **-HS HINGED SEAT OPTION INSTALLATION DETAIL - COMBYS AND TOILETS**

MANUFACTURE DATE
FEBRUARY 1999
TO PRESENT

DATE ISSUED
02/22/99
DATE REVISED
03/26/01

DRAWING NUMBER
9925-048-001

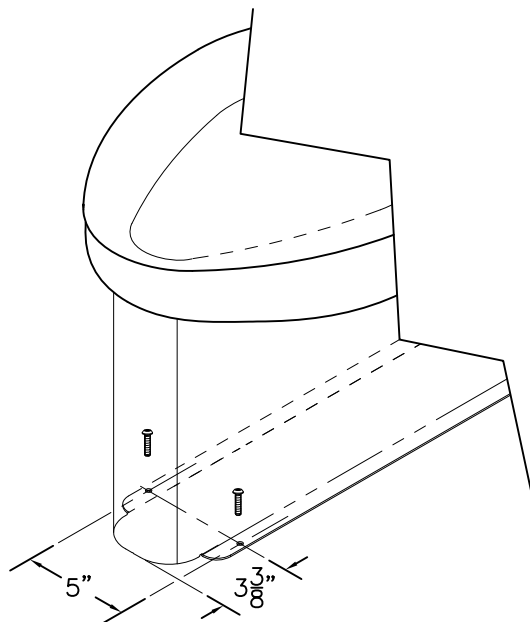
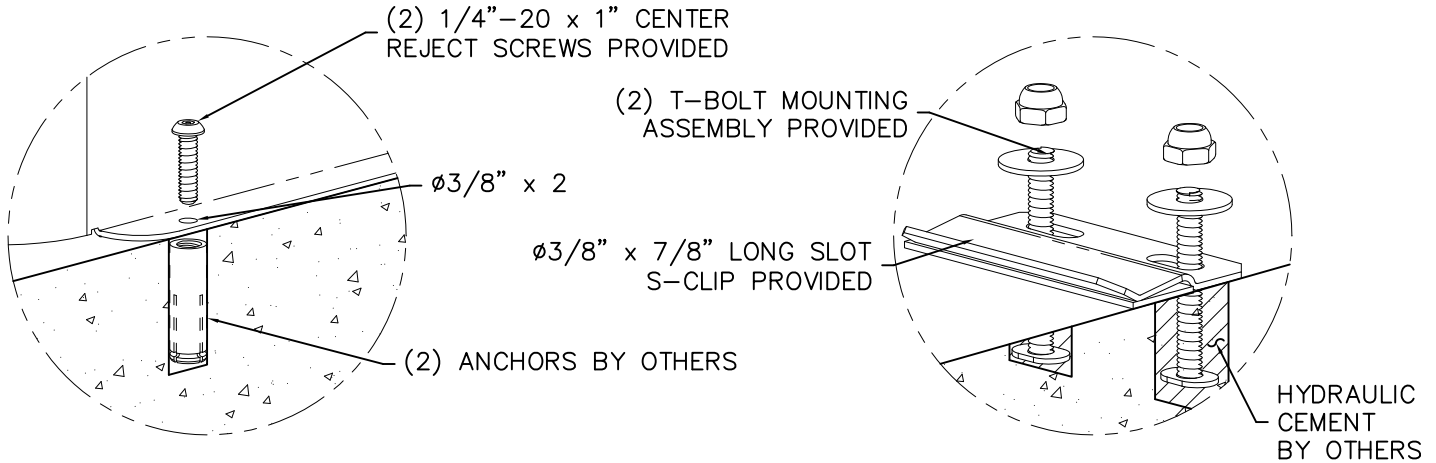

FLANGE MOUNTING

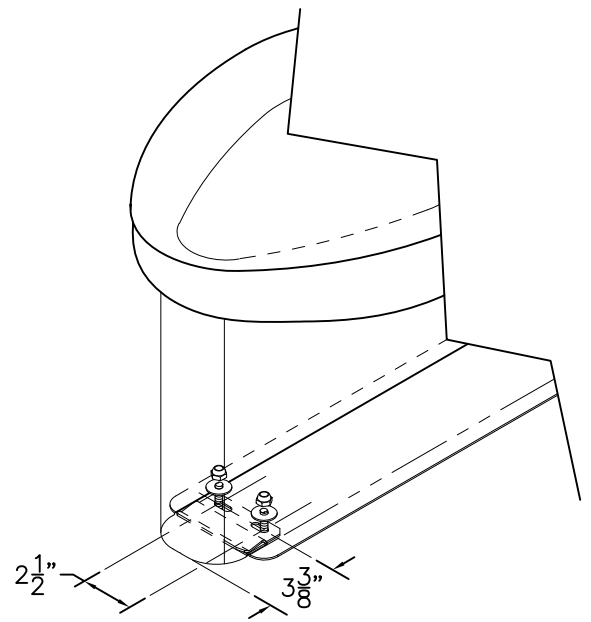

S-CLIP MOUNTING

-SS-SPS SUICIDE RESISTANT SKIRT OPTION IS PROVIDED WITH ADDITIONAL MOUNTING POINTS NOT NORMALLY PROVIDED WITH OUR STANDARD FIXTURES AND COME IN TWO STYLES AS INDICATED BELOW.

FIXTURES w/ FLANGE MOUNTING:

- A-AFTER ROUGHING IN AS REQUIRED, PLACE FIXTURE IN POSITION AND USE AS TEMPLATE TO LOCATE AND MARK FLANGE POINTS ON FLOOR.
- B-REMOVE FIXTURE AND INSTALL FLOOR ANCHORS BY OTHERS FOR 3/8" DIAMETER FLANGE PUNCHING.
- C-ALIGN WALL AND FLOOR ANCHORING POINTS AND COMPLETE FIXTURE INSTALLATION AS INDICATED BY THE FIXTURE INSTALLATION SHEET PROVIDED.

FIXTURES w/ S-CLIP:

- A-AFTER ROUGHING IN AS REQUIRED, PLACE FIXTURE IN POSITION AND USE AS A TEMPLATE TO LOCATE AND MARK S-CLIP MOUNTING LOCATION ON FLOOR AS INDICATED.
- B-REMOVE FIXTURE, INSTALL T-BOLTS FOR S-CLIP 3/8" x 7/8" LONG MOUNTING SLOTS AND SECURE WITH HYDRAULIC CEMENT (BY OTHERS)
- C-INSTALL S-CLIP
- D-PLACE FIXTURE ON FLOOR POSITIONING THE "NOSE" OF THE SKIRT SEVERAL INCHES IN FRONT OF S-CLIP MOUNTING LOCATION, SLIDE FIXTURE INTO PLACE ENGAGING THE S-CLIP AND ALIGNING WALL MOUNTING LOCATIONS. COMPLETE FIXTURE INSTALLATION AS INDICATED BY THE FIXTURE INSTALLATION SHEET PROVIDED.

<p>ACORN ENGINEERING COMPANY P.O. BOX 3527 Industry, CA 91744 15125 Proctor Ave Industry, CA 91746 (626) 336-4561 FAX (626) 961-2200</p>	<p>TITLE -SPS MOUNTING DETAIL</p>		
	<p>MANUFACTURE DATE</p> <p>AUGUST 2012</p> <p>TO PRESENT</p>	<p>DATE ISSUED</p> <p>08/15/12</p>	<p>DRAWING NUMBER</p> <p>9925-007-001</p>
		<p>DATE REVISED</p> <p>11/05/13 A</p>	

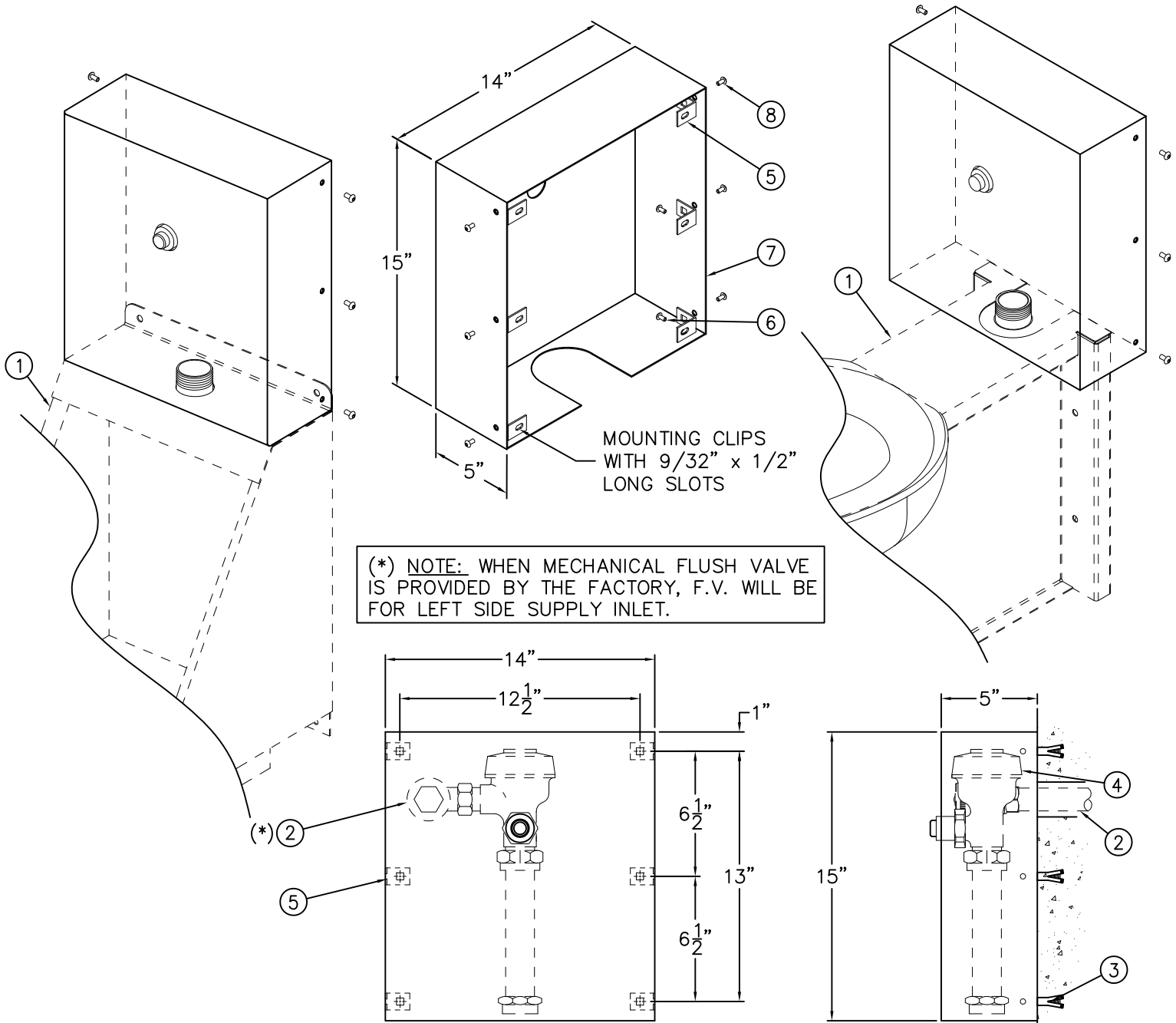

(* NOTE: WHEN MECHANICAL FLUSH VALVE IS PROVIDED BY THE FACTORY, F.V. WILL BE FOR LEFT SIDE SUPPLY INLET.

INSTALLATION INSTRUCTIONS:

- A- MOUNT FIXTURE ① TO WALL.
- B- ROUGH-IN FOR FLUSH VALVE SUPPLY ② REFER TO FIXTURE INSTALLATION INSTRUCTIONS.
- C- LOCATE AND INSTALL WALL ANCHORS (BY OTHERS) ③.
- D- INSTALL FLUSH VALVE ④ TO FIXTURE ①.
- E- ATTACH MOUNTING CLIPS ⑤ TO WALL USING MOUNTING SCREWS ⑥ (BY OTHERS).
- F- ATTACH FLUSH VALVE COVER ⑦ TO MOUNTING CLIPS ⑤ USING #10-32 SCREWS ⑧ PROVIDED.

Front View of -FVC

Side View of -FVC

Reference Drawings	
Security Screws	9951-005-001
Tinnerman Nuts	9951-007-001

NOTE: FIXTURES SHOWN FOR REFERENCE ONLY.

ACORN ENGINEERING COMPANY P.O. BOX 3527 Industry, CA 91744 15125 Proctor Ave Industry, CA 91746 (626) 336-4561 FAX (626) 961-2200	TITLE -FVC FLUSH VALVE COVER #2802	
	MANUFACTURE DATE FEBRUARY 1975 TO PRESENT	DATE ISSUED 04/17/98 DATE REVISED 12/21/16 D

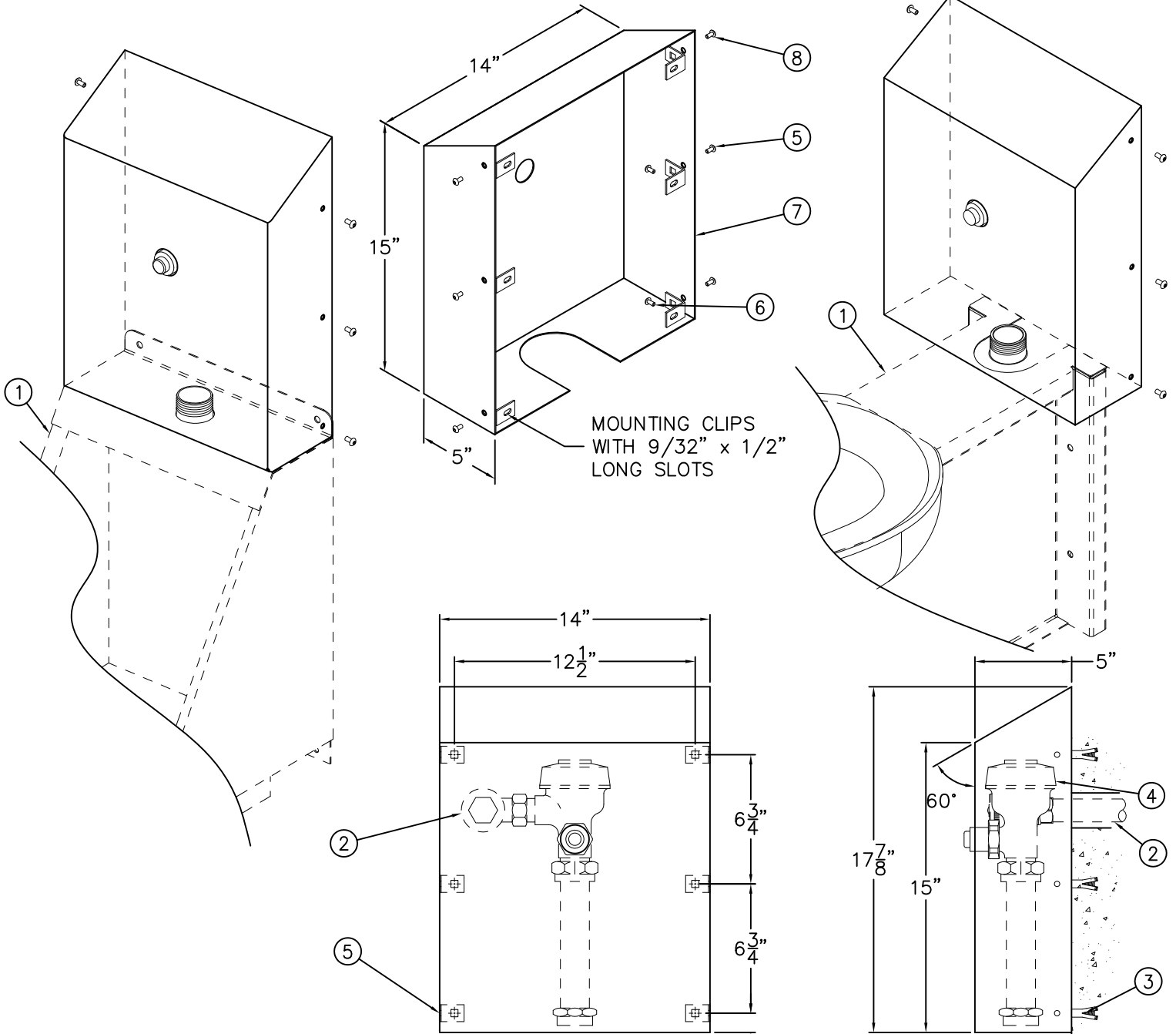

INSTALLATION INSTRUCTIONS:

- A- MOUNT FIXTURE ① TO WALL.
- B- ROUGH-IN FOR FLUSH VALVE SUPPLY ② REFER TO FIXTURE INSTALLATION INSTRUCTIONS.
- C- LOCATE AND INSTALL WALL ANCHORS (BY OTHERS) ③.
- D- INSTALL FLUSH VALVE ④ TO FIXTURE ①.
- E- ATTACH MOUNTING CLIPS ⑤ TO WALL USING MOUNTING SCREWS ⑥ (BY OTHERS).
- F- ATTACH FLUSH VALVE COVER ⑦ TO MOUNTING CLIPS ⑤ USING #10-32 SCREWS ⑧ PROVIDED.

Front View of -FVC-SLPT

Side View of -FVC-SLPT

Reference Drawings	
Security Screws	9951-005-001
Tinnerman Nuts	9951-007-001

NOTE: FIXTURES SHOWN FOR REFERENCE ONLY.

<p>ACORN ENGINEERING COMPANY P.O. BOX 3527 Industry, CA 91744 15125 Proctor Ave Industry, CA 91746 (626) 336-4561 FAX (626) 961-2200</p>	<p>TITLE -FVC-SLPT FLUSH VALVE COVER WITH SLOPING TOP #2802</p>		
	<p>MANUFACTURE DATE FEBRUARY 1975 TO PRESENT</p>	<p>DATE ISSUED 03/07/11</p>	<p>DRAWING NUMBER 9908-397-001</p>
		<p>DATE REVISED 04/15/13 E</p>	