



Dura-Ware® 2165 Series

Straddle Type Blowout Jet Urinal - ADA Compliant



2165-T-1-FV



2165-W-1-FV-2898

Fixture May Show Some Available Options

Please visit www.acorneng.com for most current specifications.

Straddle Type Blowout Jet Urinal - ADA Compliant

Fixture is arranged to be installed on finished wall and serviced from the front side. Unit conforms with ANSI, UFAS and ADA requirements for accessibility. Compliance is subject to the interpretation and requirements of the local code authority. Fixture is fabricated from 14 gage, type 304 stainless steel and is seamless welded construction. Exterior has a satin finish. Interior has a matte finish. Fixture has a back wall washdown, and is optionally available with a continuous flushing rim that washes all four walls. Corners are coved to facilitate cleaning. P-trap is fully enclosed. Back of fixture is sound-deadened with fire-resistant material.

Urinal is blowout jet type with back wall washdown. Flushing inlet connection is 1-1/2" NPT male and requires a minimum of 25 PSI flow pressure. P-trap has a minimum 2-1/2" seal.

Exposed Mounting Screws are furnished. No concealed wall fasteners or anchor shields are furnished.

GUIDE SPECIFICATION

Provide and install Acorn Dura-Ware Straddle Type Blowout Jet Urinal (specify model number and options). Urinal shall be back washdown type. Fixture shall be fabricated from 14 gage, type 304 stainless steel and shall have coved corners to facilitate cleaning. All welds shall be continuous and exterior surfaces shall have a satin finish. P-trap shall be fully enclosed. Fixture shall be furnished with exposed mounting screws. Units to conform with ANSI, UFAS and ADA requirements for accessibility.



Dura-Ware® 2165: Straddle Type Blowout Jet Urinal - ADA Compliant

WALL THICKNESS AND TYPE (Must Specify)

Thickness: _____ Type: Concrete Block Steel

MODEL NUMBER AND OPTIONS SELECTION

BASE MODEL NUMBER

2165 Straddle Type Blowout Jet Urinal

SUPPLY (Must Specify)

-T Top (Exposed)
 -W Wall (Concealed)

FIXTURE MOUNTING AND WASTE

-1 Off-Floor, Wall Outlet

FLUSH VALVE OPTIONS (Must Specify)

Refer to Acorn Dura-Ware Supplementary for Box Cover(s) and Access Panel(s)

- FV Flush Valve, Mechanical 3.5 GPF
- FVBO Flush Valve by Others
- FVH Flush Valve, Hydraulic 3.5 GPF (N/A for Top Supply)
- FVL Flush Valve, ADA Lever Handle (Concealed F.V.)
- MVCFV Time-Trol Flush Valve (N/A for Top Supply)

PRODUCT OPTIONS

- ADA 17" Rim Height
- CFR Continuous Flushing Rim
- EG Enviro-Glaze Color, Specify: _____
- FVT Flush Valve Thru Wall Connection
- TF Transformer, 120VAC to 24VAC (-MVCFV Option)
- WA1 Waste Adapter to 2" NCT Female
- WA2 Waste Adapter to 2" NPT Male
- WA3 Waste Adapter to 2" NPT Female
- WA4 Waste Adapter to 2" No-Hub

Please visit www.acorneng.com for most current specifications.

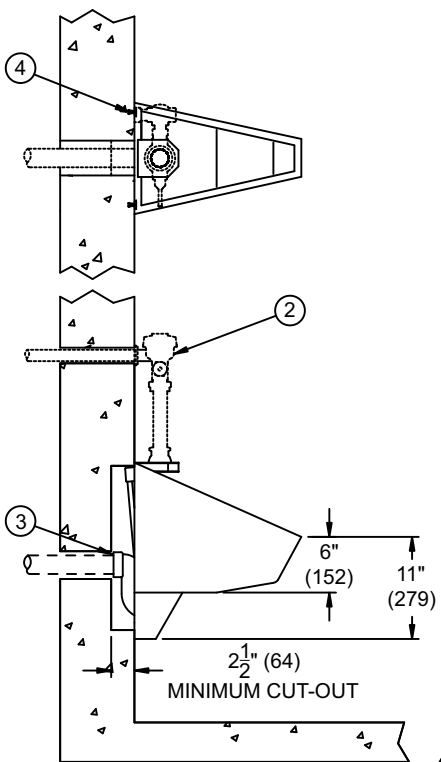

2165-T-1

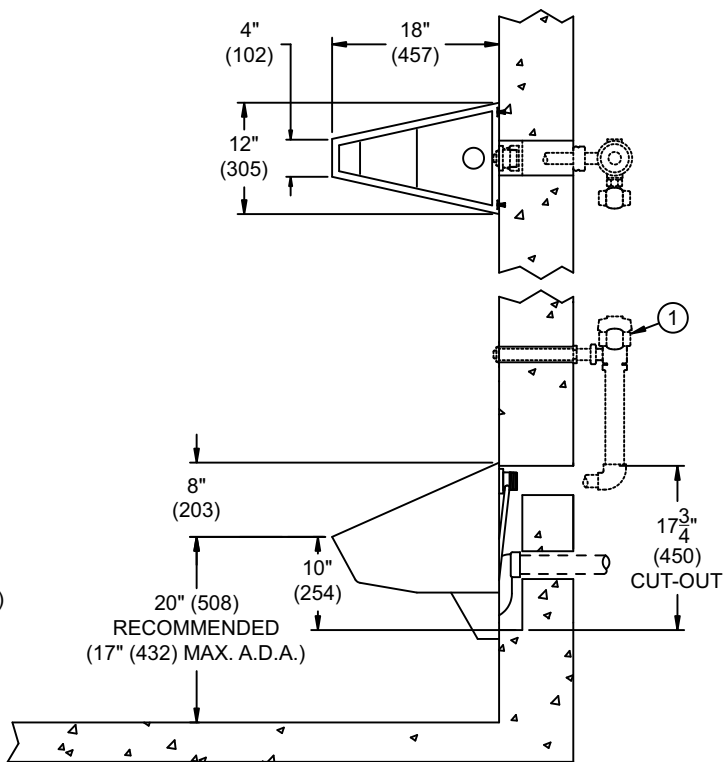

2165-W-1

NOTES:

1. Optional -FV Flush Valve - Wall Supply.
2. Optional -FV Flush Valve - Top Supply.
3. Urinal Waste Outlet.
4. Wall Mounting Anchors (By Others).

WARNING: Cancer and Reproductive Harm - www.P65Warnings.ca.gov

Important: Installation instructions and current rough-in are furnished with each fixture. Do not rough in without certified dimensions. <small>Dimensions are subject to manufacturer's tolerance of plus or minus 1/4" and change without notice. Acorn assumes no responsibility for use of void or superseded data. © Copyright 2007 Acorn Engineering Company</small>	
<p style="text-align: center;">Selection Summary</p> <p>Model No. & Option _____</p> <p>Quantity _____</p>	<p style="text-align: center;">Approved for Manufacturing</p> <p>Company _____ Title _____</p> <p>Signature _____ Date _____</p>