

ITEM	DESCRIPTION	PART NO.
1	STRAINER WASTE ASSY, PCP	6466
2	BUBBLER HEAD ASSY, PCP	5703M
3	BUTTON, PUSH, NON-FLANGED, PCP	5874PB
4	VALVE REPAIR KIT	VRK5874
5	PUSH BUTTON ASSY	PBA7
* 6	VALVE, BIB FAUCET, PCP	6250LF

\* DENOTES OPTIONAL PART.

NOTES:

- 1 5874PB (ITEM 3) INCLUDES VRK5874 CARTRIDGE ASSEMBLY (ITEM 4) AND PBA7 FLANGED PUSH BUTTON (ITEM 5).
- 2 ENSURE TUBE IS DISCONNECTED FROM PUSH BUTTON VALVE BODY PRIOR TO REMOVAL. APPLY ONE DROP OF LOCTITE 222MS TO NOZZLE THREADS PRIOR TO FASTENING BACK ONTO BUBBLER HEAD. RE-ATTACH TUBE TO VALVE.
- 3 USE MODEL 6250LF WITH ACCESS PLATE, PN 0004499489.

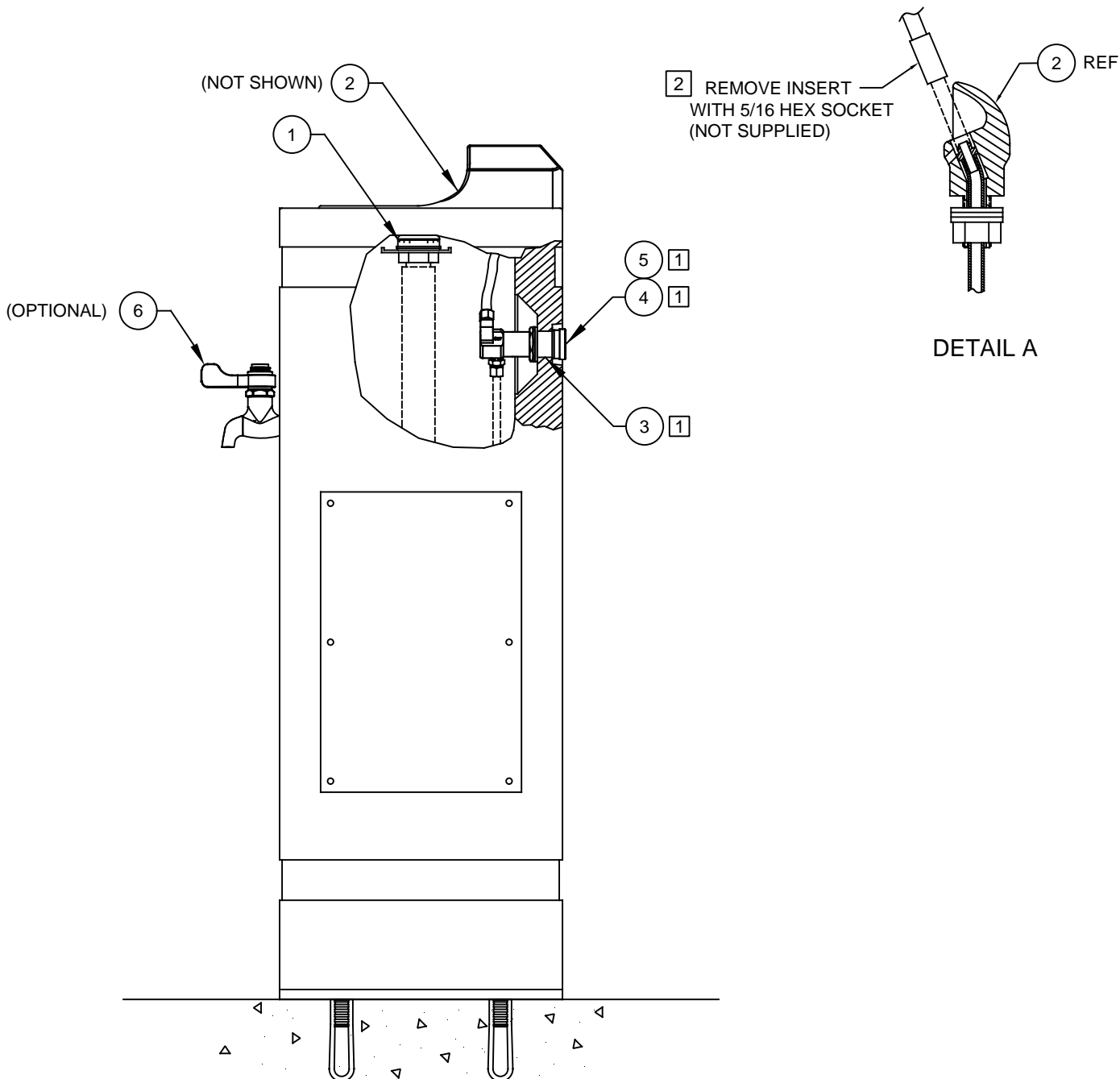

# PARTS BREAKDOWN

WHEN ORDERING PARTS PLEASE SPECIFY MODEL NUMBER.

		1455 KLEPPE LANE SPARKS, NEVADA 89431 (775) 359-4712 FAX (775) 359-7424 E-MAIL: HAWS@HAWSCO.COM WEBSITE: WWW.HAWSCO.COM	
		ECN NO. REVISED PER BY ECN: 5258 JP	MODEL(S) 3121
DRAWN D. OLLOM	DATE 11/25/95	CHKD GC	REVISION 18
APPROVED FV	DATE 11/23/17	SCALE: 1:4	DRAWING TYPE: PARTS BREAKDOWN SIZE: A SHEET 1 OF 1