



# model 3511

## Barrier-Free Aluminum Pedestal Fountain

### FEATURES & BENEFITS

#### CONSTRUCTION

Heavy-duty cast aluminum construction supports this elegant old-charm fountain, and it is finished with midnight black powder-coat paint.

#### BARRIER-FREE

Barrier-free capabilities combined with its ease of use allows for a number of installation location possibilities.

#### BUBBLER HEAD

Polished chrome-plated brass bubbler head with integral laminar flow prevents splashing while providing a superior flow pattern. The integral 11/16" dia. basin shank and stainless anti-rotation roll pin for vandal resistance strength. Shielded, angled stream opening provides a steady source of drinking water at .45 gpm.

#### DRINKING FOUNTAIN VALVE

The push-button activated valve offers the only all stainless steel valve body that is machined out of solid bar stock, is fully serviceable through the front of the push button assembly offering access to the water control cartridge and integral water supply strainer, and with front access to the water stream height adjustment for easy maintenance without having to remove the valve. Operating pressure range of 30 to 90 psi (2.1 to 6.2 bar).

#### FOUNTAIN PUSH BUTTON

All chrome plated brass push button resists vandalism by allowing it to spin without unscrewing.



### SPECIFICATIONS

Model 3511 "Hi-Lo" barrier-free antique style pedestal drinking fountain shall include a heavy duty cast aluminum pedestal with a black powder-coated finish, dual 18 gauge Type 304 Stainless Steel satin finish basins with integral swirl design, 100% lead-free waterways, push-button operated stainless steel valves with front-accessible cartridge and flow adjustment, polished chrome-plated brass vandal-resistant bubbler heads, chrome-plated brass vandal-resistant waste strainer, integral mounting plate, and 1-1/2" O.D. tailpiece.

### OPTIONS

- ❑ Sand Trap: Model 6611, sand trap for installing adjacent to pedestal drinking fountains to help prevent debris and contaminants from clogging waste line.
- ❑ Sand Trap: Model 6635, in-pedestal sand trap for models 3500, 3511 and 3600 series fountains.
- ❑ Faucet Valve: Model 6250LF, self-closing, plain end, lead-free, brass bib faucet with polished chrome-plated finish. (When used with Haws concrete products, also order part 0004499489; for 3511, use 0004521763)

For more information, visit [www.hawsco.com](http://www.hawsco.com) or call (888) 640-4297.

### APPLICATIONS

Indoor or outdoor architectural settings where an "old town" ambiance is present, the 3511 fits perfectly. Historic styled fountain with "up to date" components that provide performance really bring a traditional feel to any area that is historically designed. Powder-coated finish helps maintain the fountains overall appeal so it remains looking as it did when it was newly installed. This type of pedestal drinking fountain may also be placed in a variety of settings such as: parks, schools, and other outdoor environments where the temperature remains above freezing. Model meets all current Federal Regulations for the disabled including those in the Americans with Disabilities Act. Haws manufactures drinking fountains and electric water coolers to be lead-free by all known definitions including NSF/ANSI Standard 61, Section 9, NSF/ANSI 372, California Proposition 65, and the Federal Safe Drinking Water Act. Product is compliant to California Health and Safety Code 116875 (AB 1953-2006).



**NOTES:**

1. REFER TO 5874 SERIES OPERATION AND MAINTENANCE MANUAL FOR PUSH BUTTON AND VALVE INSTALLATION/MAINTENANCE INSTRUCTIONS.
2. OPTIONAL SAND TRAP MODEL 6635 W/ MOUNTING PLATE AND 1-1/2" O.D. TAILPIECE. SEE MODEL 6635 FOR ADDITIONAL INSTALLATION INSTRUCTIONS.

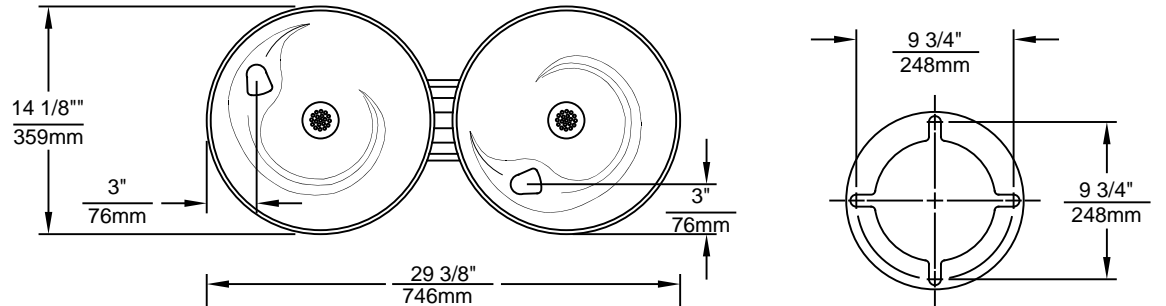

**MOUNTING DETAIL**

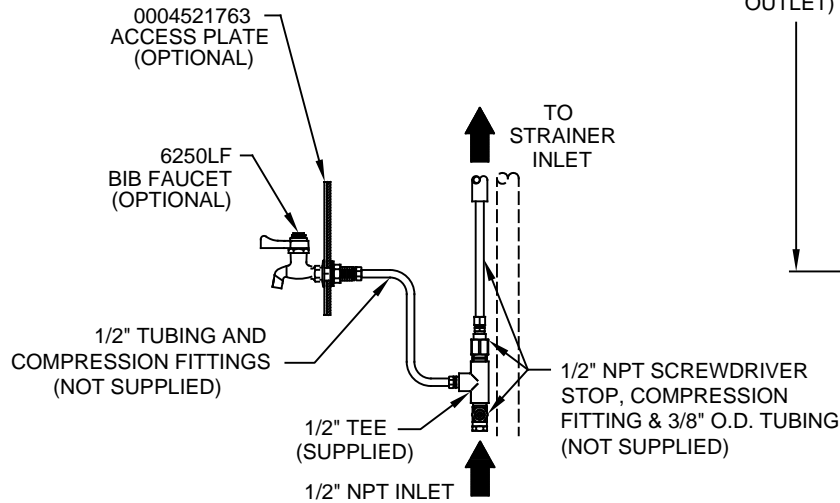
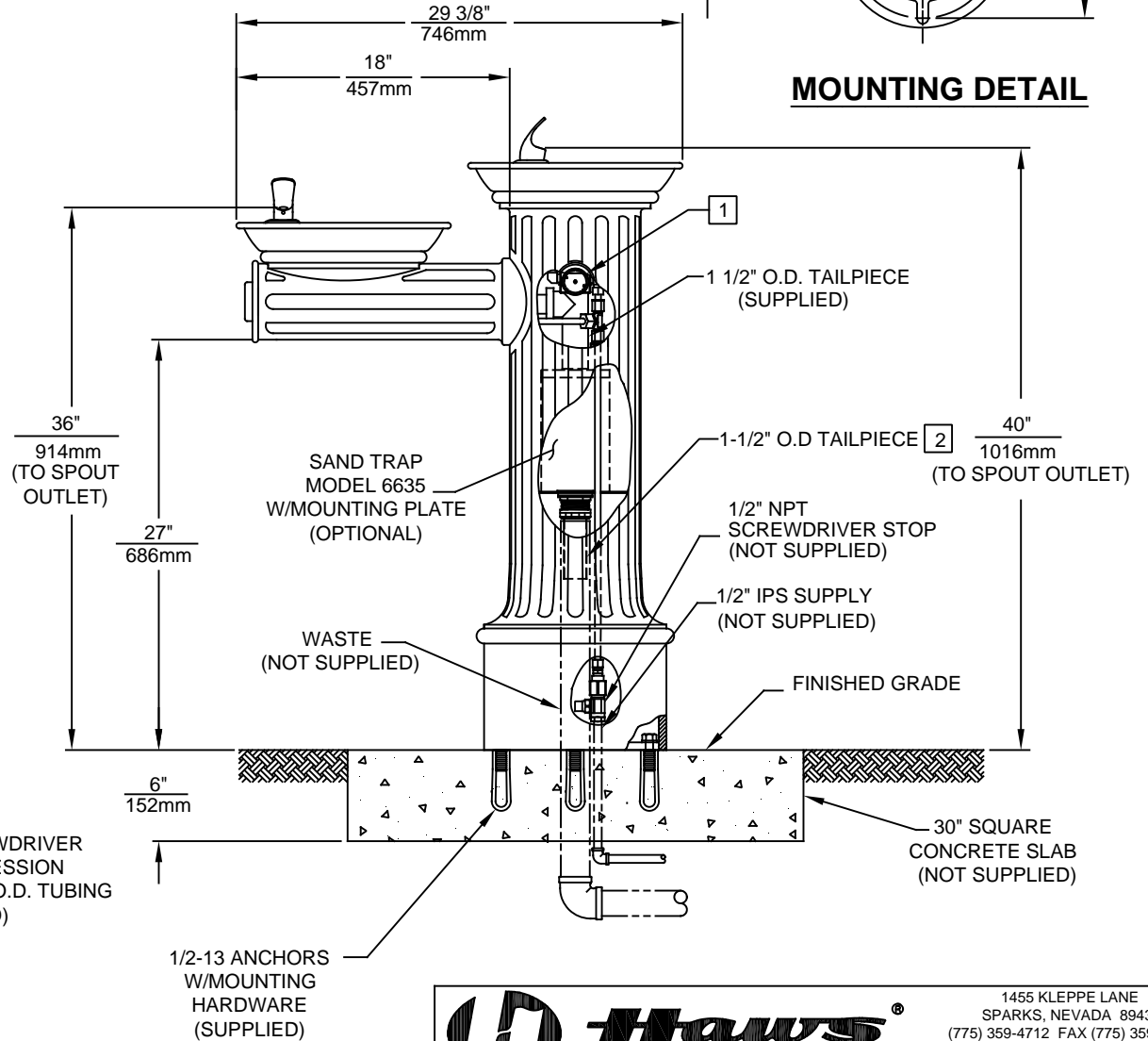

**BIB FAUCET DETAIL**

1455 KLEPPE LANE  
SPARKS, NEVADA 89431  
(775) 359-4712 FAX (775) 359-7424  
E-MAIL: HAWS@HAWSCO.COM  
WEBSITE: WWW.HAWSCO.COM

ECN NO. REVISED PER BY:		MODEL(S)		3511	PART NUMBER 0002074001.D
5438	FV				
DRAWN:	DATE:	CHKD.:			REVISION
P.M.	05-30-00	DP			18
APPROVED:	DATE:	SCALE: 1:8		DRAWING TYPE: INSTALLATION	SIZE: A
IR	12/09/19				SHEET 1 OF 1