

4896-FA Series 49" Wide Handicap- ADA Front Access Combination Lavatory/ Toilet Unit for use on 90 degree wall

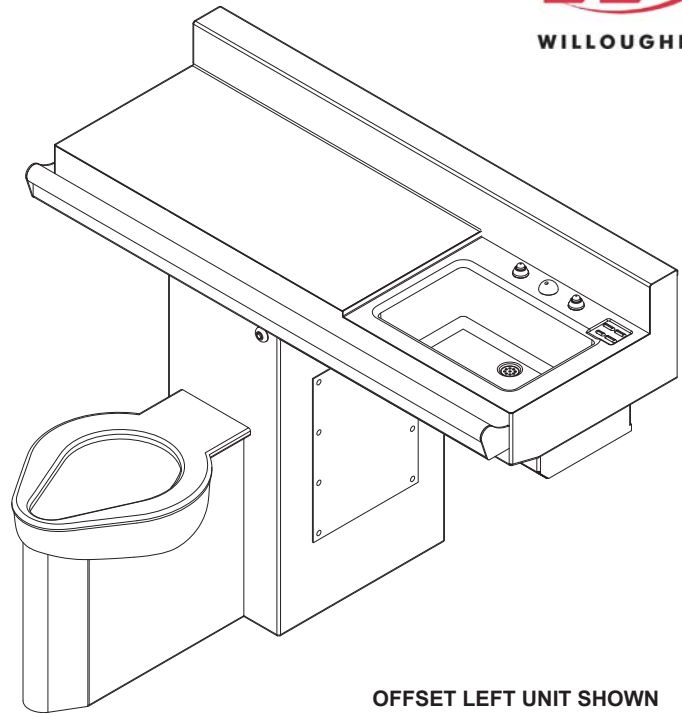

IN COMPLIANCE
WITH A.D.A. 2010
& CBC 2016, 11B*



OFFSET LEFT UNIT SHOWN
(Unit may be shown with optional features)

Recommended Specifications

49" Wide Handicap-ADA Front Access Combination Lavatory/Toilet Unit for use on 90 degree wall shall be:

Willoughby Model No. **EC__4896-FA**

(Select from model number and options list on next page)

Fixture shall be fabricated from 14 gauge, type 304 stainless steel. The construction shall be all welded, with exposed stainless surfaces polished to a #4 satin finish. Removable access panels, attached w/ security screws shall provide access to fixture interior.

Standard toilet shall include:

- Ligature resistant toilet skirt (extends to floor)
- Elongated toilet bowl with contoured seat
- Integral crevice-free self-draining flushing rim with positive afterfill
- Bead blast finish bowl interior

Toilet shall be blowout type, requiring 35 psi min. flushing pressure. Model shall meet the requirements of ASME A112.19.3/CSA B45.4.

Standard lavatory shall include:

- Rectangular-shaped bowl, 14" x 9-1/2" x 4-3/8" deep
- Stainless steel ligature-resistant bubbler/filler
- Slow drain with air vent
- Self-draining soap dish
- Removable slip-joint brass union 'P' trap (1-1/2" N.P.T.)

An integral behind-toilet grab bar with ligature-resistant closure plate is provided standard.

To specify fixture and accessories, use the Model Number and Options page.

Example: To specify a Front Access Ligature-resistant Handicap-ADA Compliant 49" wide (90° Chase) Combination Lavatory/Toilet with wall outlet, offset left toilet, standard ligature-resistant deck mounted bubbler, 1.6 GPF, dual temp. pneumatic metering valve, standard ligature-resistant pneumatic push buttons, removable lav. 'p' trap, lav. slow drain, toilet waste extension, standard gasketed waste connection, hydraulic flush valve, and wall template

Use the following Willoughby Model Number:

ECW-4896-FA-L-ON-DMBH-1.6-PML2-PBH-RPT-SLOW-GWC-FV-MT

Fixture shall withstand loadings of 5,000 lbs. without permanent damage. Cabinet interior shall be sound deadened with fire-resistant material.

Optionally selected lavatory valve and flush valve shall be factory installed inside fixture cabinet.

Anchoring shall be from the front, anchoring holes provided. Anchoring hardware provided by others. Standard unit requires no chase area for installation and maintenance, however certain non-standard options may require an accessible chase (see options list for details).

On back to back fixture installations, do not use standard cross type waste fitting: cross flow may result due to blowout jet action. Use sanitary or offset type waste fittings.

Note: Unit will pass a 2" ball.

Note: Fixture should only be used with a listed high-efficiency flushometer to ensure the complete system meets the requirements of WaterSense.



WARNING: Cancer and Reproductive Harm

- www.P65Warnings.ca.gov



MADE IN THE U.S.A.

visit our website at www.willoughby-ind.com
5105 West 78th Street • Indianapolis, IN. 46268
(317) 875-0830 • Fax: (317) 875-0837 • (800) 428-4065

MODEL NUMBER AND OPTIONS:

1.) Toilet Waste Location:

- ECW Wall Outlet
- ECF Floor Outlet

2.) Base Model Number:

- 4896-FA 49" Wide Handicap-ADA Front Access Combination Lavatory/Toilet Unit for use on 90 degree chase wall

3.) Toilet Orientation:

- L Offset Left
- R Offset Right

4.) Fixture Mounting:

- ON On-Floor

5.) Bubblers Selection:

- DMBH Ligature-resistant Deck Mounted Bubbler (Standard)

6.) Flush Valve GPF (Must Specify):

- 1.28 GPF HET (4.8 Lpf) (WaterSense Labeled)
- 1.6 GPF ULF (6.0 Lpf)
- 3.5 GPF (13.2 Lpf)

7.) Lavatory Valve Selection:

- NV No Valve
- PSL1 Single Temp. Pneumatic Non-metering
- PSL2 Dual Temp. Pneumatic Non-metering
- PML1 Single Temp. Pneumatic Metering
- PML2 Dual Temp. Pneumatic Metering
- E1L1 Single Temp. Electronic (Pick Control)
- E1L2 Dual Temp. Electronic (Pick Control)

8.) Lavatory Push Button Selection:

- PBH Ligature-resistant Pneumatic Push Buttons
- PZPB Ligature-resistant Piezo Electronic Push Buttons

9.) Electronic Controls*

(Must Use Electronic Lavatory & Flush Valves):

- WUCC-3010 Pneutronic WMSII

10.) Lavatory Waste:

- RPT Removable 'P'-Trap (1-1/2" N.P.T.) (Standard)
- OV Lavatory Overflow
- CW1 Combined Waste w/o Clean-out
- CW2 Combined Waste w/ Clean-out
- SLOW Slow Drain (Standard)

11.) Toilet Waste:

- GWC Gasketed Waste Connection (Standard)
- TWE Toilet Waste Extension (Requires Accessible Chase)
- TW4 Floor Outlet Waste Connection

12.) Waste Coupling for (TWE) Toilet Waste Extension:

- TWC3P Connecting to 3" PVC
- TWC3C Connecting to 3" Cast Iron
- TWC4P Connecting to 4" PVC
- TWC4C Connecting to 4" Cast Iron

*(Req. 110V power through ground fault interrupter (GFCI) receptacle)

13.) Other Options:

- T4 Manual Reset Toilet Overflow Preventer, Req. (FV)
- T4A Auto Reset Toilet Overflow Preventer, Req. (FV)
- ET4 Electronic Toilet Overflow Preventer, Requires (EFV) & (WUCC-3010) or (WMSII)
- FV Hydraulic Flush Valve (Includes Push Button)
- EFVP Electronic Flush Valve w/ (PZPB) (Pick Control)
- HS Hinged White Plastic Seat (Not recommended for Max. Security/Ligature-resistant use; No Cover)
- RTH Recessed Tissue Holder **(Not ADA Compliant)** (Underneath Lav. Bowl)
- TB1 Single Toothbrush Holder (Not Ligature-resistant), (Located beside Lav. Bowl, opposite Toilet)
- TB2 Dual Toothbrush Holder (Not Ligature-resistant), (Located beside Lav. Bowl, opposite Toilet)
- TH1 Single Towel Hook (Located beside Lav. Bowl, opposite Toilet)
- TH2 Dual Towel Hook (Located beside Lav. Bowl, opposite Toilet)
- DC Decorator Color (Fixture exterior only - White)
- TF24H Hard-wired Transformer, 110VAC to 24VAC*
- TF24P Plug-in Transformer, 110VAC to 24VAC*
- HPS High Polish Seat
- MT Wall Template
- WS Wall Sleeve (Requires Accessible Chase)
- TG 12 Gauge Cabinet
- TSC Toilet Shipping Cover
- LSK Less Ligature-resistant Toilet Skirt
- DFBH Ligature-resistant DM Drinking Fountain Bubbler** (Panel Mounted Push Button)
- Other _____
- Other _____

Approved For Manufacturing By: _____ Date: _____ Company: _____
 Wall Thickness: _____ Wall Type: _____

VERIFY ALL DIMENSIONS WITH FACTORY PRIOR TO ROUGH-IN
 WILLOUGHBY RESERVES THE RIGHT TO MAKE CHANGES IN DESIGN AND DIMENSIONS WITHOUT FORMAL NOTICE AND WITHOUT INCURRING OBLIGATION.

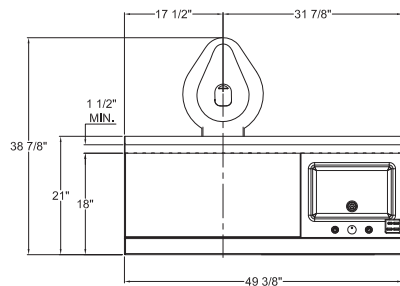

PLAN VIEW-RIGHT HAND CONFIGURATION

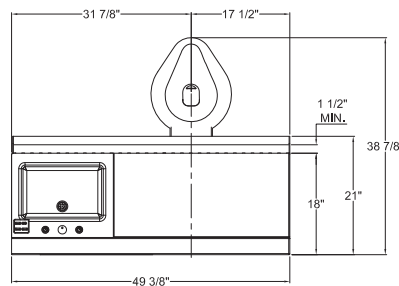

PLAN VIEW-LEFT HAND CONFIGURATION

IN COMPLIANCE WITH A.D.A. 2010

IN COMPLIANCE WITH C.B.C. 2016, 11B

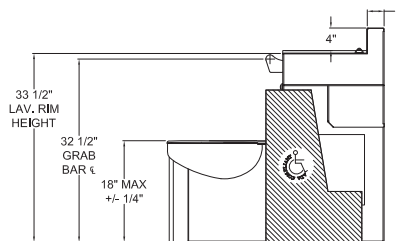

SIDE VIEW (LEFT HAND CONFIGURATION)

visit our website at www.willoughby-ind.com
 5105 West 78th Street • Indianapolis, IN. 46268
 (317) 875-0830 • Fax: (317) 875-0837 • (800) 428-4065



MADE IN THE U.S.A.