



CONTEMPORARY HYDRATION

A192-BF Series

BARRIER FREE, BI-LEVEL, WALL MOUNTED DRINKING FOUNTAIN WITH BOTTLE FILLER AND 42" TRIM PANEL

STANDARD FEATURES

- Both Child or Adult ADA Compliant (when properly installed)
- 304 Stainless Steel Basin and flush mounted Chrome Plated Brass Button
- Polished Stainless Steel, anti-rotation non-squirt Bubbler or Flexible Low Flow Bubbler
- 100-Mesh Inlet Strainer
- Mounting Plate and Hardware
- 42" Wide Trim Panel
- 1 G.P.M. Fill Rate (Bottle Filler)
- Laminar Flow Water Supply (Bottle Filler)
- 115v Plug-in Transformer (Bottle Filler with Sensor Op)



Model A192400S-BF12-BCD Shown
Patent D873,606 #10,100,933

SUGGESTED SPECIFICATIONS

Drinking Fountain

Model A192400S-BF is a wall mounted, pressurized Bi-Level Drinking Fountain and Bottle Filler combination. Basin shall be constructed from 304 Stainless Steel and have an Integral Drain. Cabinet shall be made from 18 gage, 304 stainless steel with a brushed finish. Unit shall be activated by chrome plated brass Pushbutton using less than 5 pounds of force. Bubblers shall be polished stainless steel with non-squirt features and operate on a water pressure range of 20-105 PSIG. Unit shall have uniquely designed, two-piece contoured Bowls with P-Traps integral to the unit. Unit is certified to ANSI A117.1, Public Law 111-380 (NO-LEAD), CHSC 116875 and NSF/ANSI 61, Section 9. Fixture meets ADA, ADA Standing Person, and ADA Child requirements when mounted appropriately.

Bottle Filler

Bottle Filler housing construction will be 20 gage Stainless Steel with a satin finish and will also include components manufactured from Antimicrobial, impact resistant ABS. Bottle Filler shall provide approximately 1 GPM flow rate with a Laminar Flow Spout to minimize splashing.

Bottle Filler -BF11 shall include Pushbutton Operated activation.

Bottle Filler -BF12 shall include Sensor Operated activation with a 20 second maximum run time. LED Lights illuminate the Bottle Fill area and brighten when a bottle is detected. Optional -BCD Bottle Counter Display indicates the quantity of 16 oz disposable Plastic Bottles saved from a land fill and also displays the Water Filter status.

MODEL:

(Must Specify Drinking Fountain)

FLEXIBLE BUBBLER

- A192400F-BF11 Bi-Level Drinking Fountain and Bottle Filler with Pushbutton Operation
- A192400F-BF12 Bi-Level Drinking Fountain and Bottle Filler with Sensor Operation
- A192400F-BF12-BCD Bi-Level Drinking Fountain and Bottle Filler with Sensor Operation and Bottle Counter Display

STAINLESS STEEL BUBBLER

- A192400S-BF11 Bi-Level Drinking Fountain and Bottle Filler with Pushbutton Operation
- A192400S-BF12 Bi-Level Drinking Fountain and Bottle Filler with Sensor Operation
- A192400S-BF12-BCD Bi-Level Drinking Fountain and Bottle Filler with Sensor Operation and Bottle Counter Display

WATER COOLER OPTIONS

(additional costs may be incurred)

- RBL Reverse bi-level (Bottle Filler Opposite)
- SK8 Skirt kit, stainless steel, for upper unit
- WF1 1500-gallon capacity, NSF 42+53, 1 micron Lead Reduction Filter
- WF3 3000-gallon capacity, NSF 42+53, 1 micron Lead Reduction Filter

Complies with the following standards:



NSF/ANSI 61



WARNING: Cancer and Reproductive Harm - www.P65Warnings.ca.gov

MURDOCK MFG. • 15125 Proctor Avenue • City of Industry, CA 91746 USA
Phone 800-453-7465 or 626-333-2543 • Fax 626-855-4860 • www.murdockmfg.com

Member of
MORRIS GROUP
INTERNATIONAL



CONTEMPORARY HYDRATION



Member of
U.S. Green
Building
Council



Recyclable
Product



Water
Conserving
Product

A192-BF Series

BARRIER FREE, BI-LEVEL, WALL MOUNTED
DRINKING FOUNTAIN WITH BOTTLE
FILLER AND 42" TRIM PANEL

GENERAL NOTES:

1. ALL DIMENSIONS ARE IN INCHES [MM]
- *2. DIMENSIONS SHOWN ARE FOR RECOMMENDED ADULT HEIGHT. ADJUST VERTICAL DIMENSIONS AS NECESSARY TO COMPLY WITH FEDERAL, STATE, & LOCAL CODES

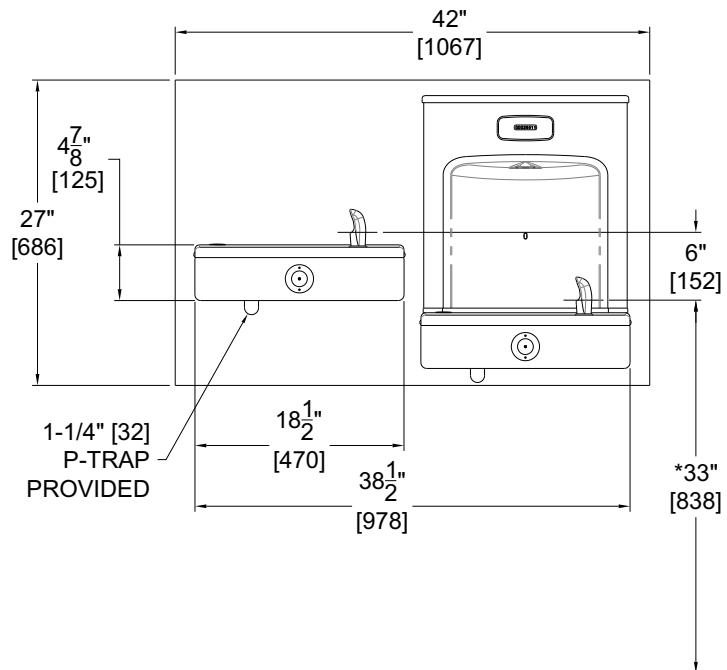
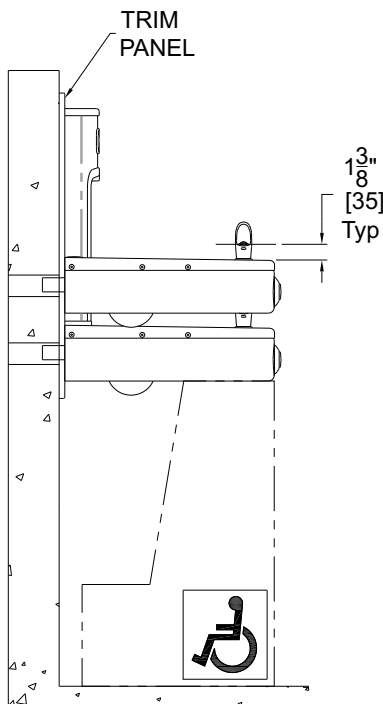
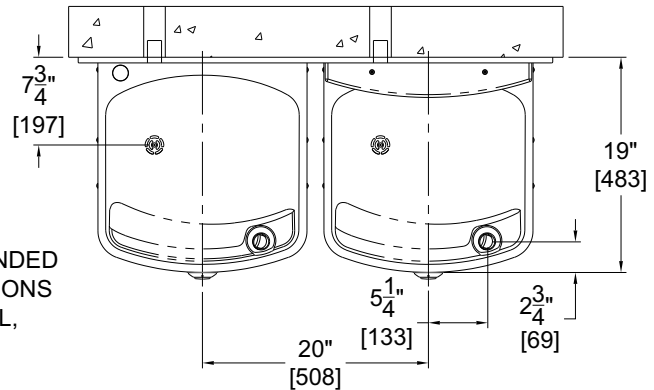

Murdock Mfg.™ warrants that its products are free from defects in material or workmanship under normal use and service for a period of one year from date of shipment. Murdock's liability under this warranty shall be discharged solely by replacement or repair of defective material, provided Murdock™ is notified in writing within one year from date of shipment, F.O.B. Industry, California.

**SELECTION SUMMARY
& APPROVAL FOR
MANUFACTURING**

Model Number & Options _____ Quantity _____

Company _____

Contact _____ Title _____

Signature _____ Date _____
(Approval for Manufacturing)

All dimensions are subject to manufactures tolerance of plus or minus 1/2" nominal and subject to change without notice. Murdock assumes no responsibility for use of void or superseded data. Dimensions may change with the addition of optional accessories. Murdock Mfg.™, Member of Morris Group International™. Please visit www.murdockmfg.com for most current specifications.