



Location:

Temptrol[®] Commercial

C-96-600-B30-V-X,
C-96-600-B30-V-TRM & C96600B30TRMTC
Tub/Shower/Hand Shower System & Trim
Specification Submittal



Feature Highlights

- Temptrol Commercial Tub/Shower/Hand Shower System or Trim
- Requires Temptrol[®] Pressure Balancing Tub/Shower Valve (included with C-96-600-B30-V-X)
- Requires Symmons Triple Outlet Diverter Valve (included with C-96-600-B30-V-X)
- Integral service stops allow water shutoff at valve for service (included with C-96-600-B30-V-X)
- Adjustable stop screw to limit hand turn (included with C-96-600-B30-V-X)
- Metal lever handles
- Dual checks for backflow protection
- 30" slide bar for hand shower
- 60" flexible metal hose
- 5-1/4" non-diverter tub spout
- 1 mode showerhead
- 1 mode hand shower
- 2.5 gpm (9.5 L/min) flow restrictor
- Components shall be metal and nonmetallic construction, plated in standard Polished Chrome finish
- Available with TA-10 flow control spindle and T-12A cap assembly for Temptrol valve bodies installed with Test Cap (order p/n C96600B30TRMTC)

Model Numbers

- C-96-600-B30-V-X**
Tub/Shower/Hand Shower System with Temptrol Pressure Balancing Tub/Shower Valve and Symmons Triple Outlet Diverter Valve
- C-96-600-B30-V-TRM**
Tub/Shower/Hand Shower Trim, Temptrol Pressure Balancing Tub/Shower Valve and Symmons Triple Outlet Diverter valve ordered separately
- C96600B30TRMTC**
Tub/Shower/Hand Shower Trim with TA-10 flow control spindle and T-12A cap assembly, must order Temptrol valve with Test Cap

Compliance



- ASME A112.18.1/CSA B125.1



Warranty

Limited Lifetime - to the original end purchaser in consumer/residential installations.
5 Years - for industrial/commercial installations.
Refer to www.symmons.com/warranty for complete warranty information.
Go to www.symmons.com/register to register your Symmons product.

Options/Modifications

- 2.0** 2.0 gpm (7.6 L/min) flow restrictor
- 72** 72" hose in place of 60" hose
- 231** Super showerhead
- ADAHS** ADA hand shower wand (white)
- Delete Suffix B30** 2 wall hooks in place of 30" bar
- B48** 48" adjusting bar in place of 30" bar
- L1** Less showerhead
- L2** Less hand shower
- L3** Less showerhead & hand shower wand
- LAM**  Metal finish insert handle
- LP**  Loop handle
- NS**  Non-shared diverter valve
- QD** Quick-disconnect on hand shower units
- R** 60" white vinyl hose in place of 60" metal hose
- REB** Rebuild trim kit, includes TA-10 and TA-4
- SS** Slip spout
- T24** 24" slide bar/grab bar with white ADA wand
- T36** 36" slide bar/grab bar with white ADA wand
- T48** 48" slide bar/grab bar with white ADA wand
- T724** 24" slide bar/grab bar with chrome ADA wand
- T736** 36" slide bar/grab bar with chrome ADA wand
- T748** 48" slide bar/grab bar with chrome ADA wand
- VB** Elevated vacuum breaker
- VP** Vandal resistant escutcheon screws in place of standard screws
- Delete Suffix X** Less integral service stops
- CHKS** Integral check stops - for use in installations where a positive shut-off device is used downstream of mixing valve

Note: Append appropriate -suffix to model number.

Dimensions

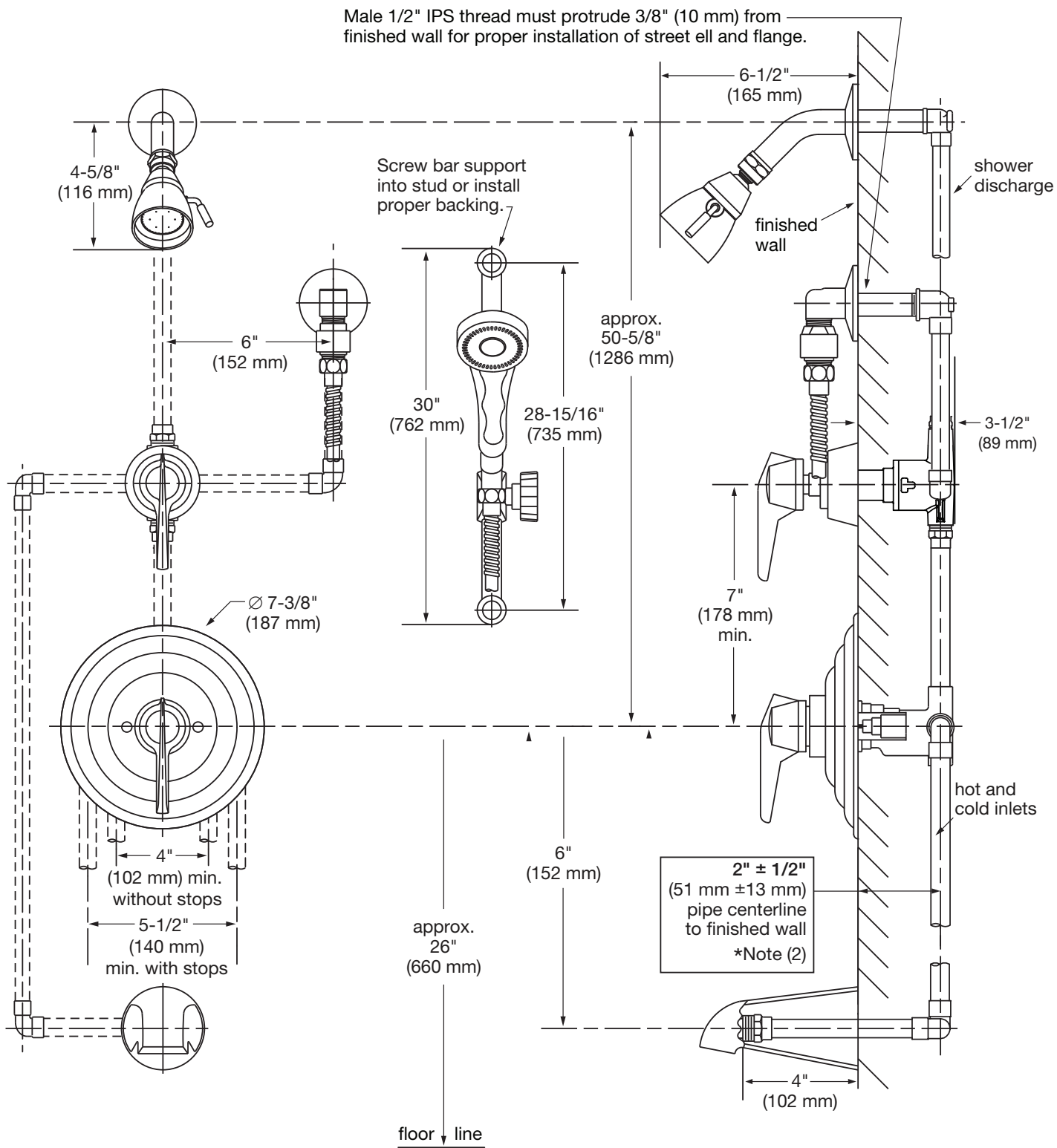

Notes:

- 1) Valve body and piping not included and shown as reference only.
- 2) Plaster shield (p/n T-176) for dry wall, plaster or other type walls 1/2" or greater.
- 3) All dimensions measured from nominal rough-in.
- 4) Dimensions subject to change without notice.