

## FD-1400 Detox Toilet

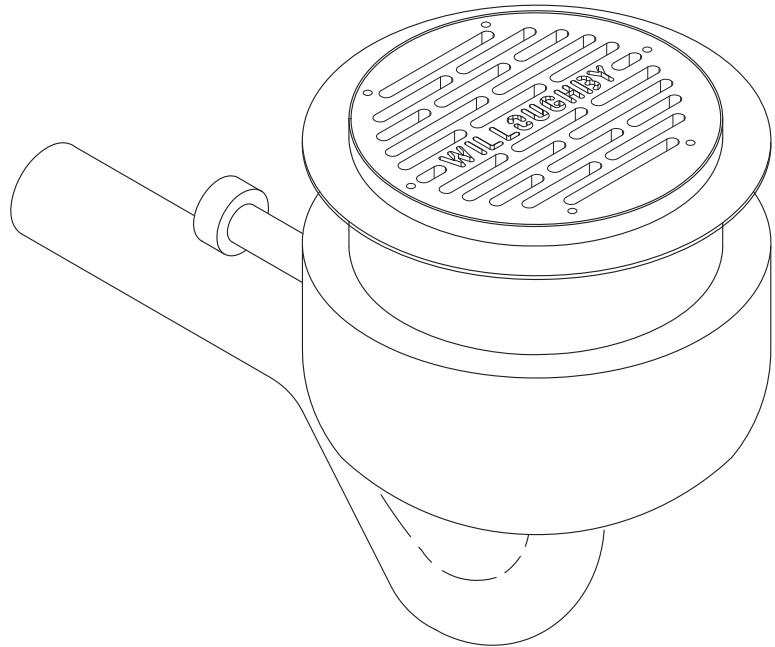

*(Unit may be shown with optional features)*

To specify fixture and accessories, use the Model Number and Options page.

Example: To specify an FD-1400 detox with flange, 3.5 GPF (13.2 Lpf), and remote flush valve with wall box

Use the following Willoughby Model Number:

**FD-1400-WF-3.5-RFVB**

### Recommended Specifications

Detox Toilet shall be:

Willoughby Model No. **FD-1400**

(Select from model number and options list on next page)

Fixture shall be fabricated from 14 gauge, type 304 stainless steel.

The construction shall be all welded, with exposed stainless surfaces polished to a #4 satin finish.

Standard equipment shall include:

- 14" diameter round bowl with 2" top band
- Removable 7 GA. S/S top grate for access to bowl interior
- Integral crevice free flushing rim with positive afterfill  
(1" wide full perimeter flange is standard on FD-1400-WF fixture for padded cell installations)

Toilet shall be blowout type, requiring 35 PSI minimum flushing pressure. Trap shall be fully enclosed, maintain a minimum 3-1/2" seal and pass a 2-5/8" ball.

Note: For ULF 1.6 GPF, unit will pass a 2-1/8" ball.

visit our website at [www.willoughby-ind.com](http://www.willoughby-ind.com)

5105 West 78th Street • Indianapolis, IN. 46268

(317) 875-0830 • Fax: (317) 875-0837 • (800) 428-4065



MADE IN THE U.S.A.

# MODEL NUMBER AND OPTIONS:

**1.) Base Model Number:**

- FD-1400

**2.) Flange:**

- LFL Less Flange
- WF With Flange

**3.) Flush Valve GPF (Must Specify):**

- 3.5 GPF (13.2 Lpf) (Standard, 3" waste tube required)
- 1.6 GPF ULF (6.0 Lpf)

**4.) Other Options:**

- FV Hydraulic Flush Valve (Includes Actuator)
- AP Flush Valve Access Panel
- RFVB Remote Flush Valve with Box
- REFVB Remote Electronic Flush Valve with Box\*
- RMPB Remote Mounted Flush Valve Push Button (Must be located within 10' of Flush Valve)
- HB-8156 Dual Temp. Single Outlet Hose Box
- EFV Electronic Flush Valve (Pick Control)\*
- EFVP Electronic Flush Valve w/ (PZPB) Ligature-resistant Piezo Push Button (Pick Control)\*
- TF24H Hard-wired Transformer, 110/24VAC\*
- TF24P Plug-in Transformer, 110/24VAC\*
- Other \_\_\_\_\_

**5.) Electronic Controls (Must Use Electronic Flush Valve):**

- WUFC-4000  Pneutronic  WMSII
- WUCC-3010 (Select WUCC-3010 Control if pairing a Detox Toilet with a Lavatory)

\*(Req. 110V power through ground fault interrupter (GFCI) receptacle)

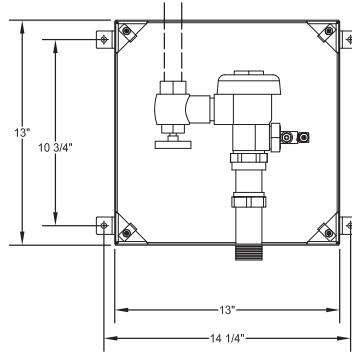

FRONT VIEW  
COVER REMOVED

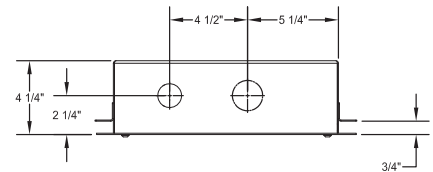

TOP VIEW

## Recommended Specifications: RFVB

Remote flush box with integral flush valve shall be:  
Willoughby Model No. **RFVB**

The front cover shall be fabricated from 14 gauge, type 304 stainless steel with exposed surfaces polished to a #4 satin finish.

The cover shall be mounted to the wall box with security screws. The wall box and wall brackets shall be fabricated from 20 gauge galvanized steel.

The integral flush valve shall be non-hold open type.

Approved For Manufacturing By: \_\_\_\_\_ Date: \_\_\_\_\_ Company: \_\_\_\_\_

Wall Thickness: \_\_\_\_\_ Wall Type: \_\_\_\_\_

VERIFY ALL DIMENSIONS WITH FACTORY PRIOR TO ROUGH-IN  
WILLOUGHBY RESERVES THE RIGHT TO MAKE CHANGES IN DESIGN AND DIMENSIONS WITHOUT FORMAL NOTICE AND WITHOUT INCURRING OBLIGATION.

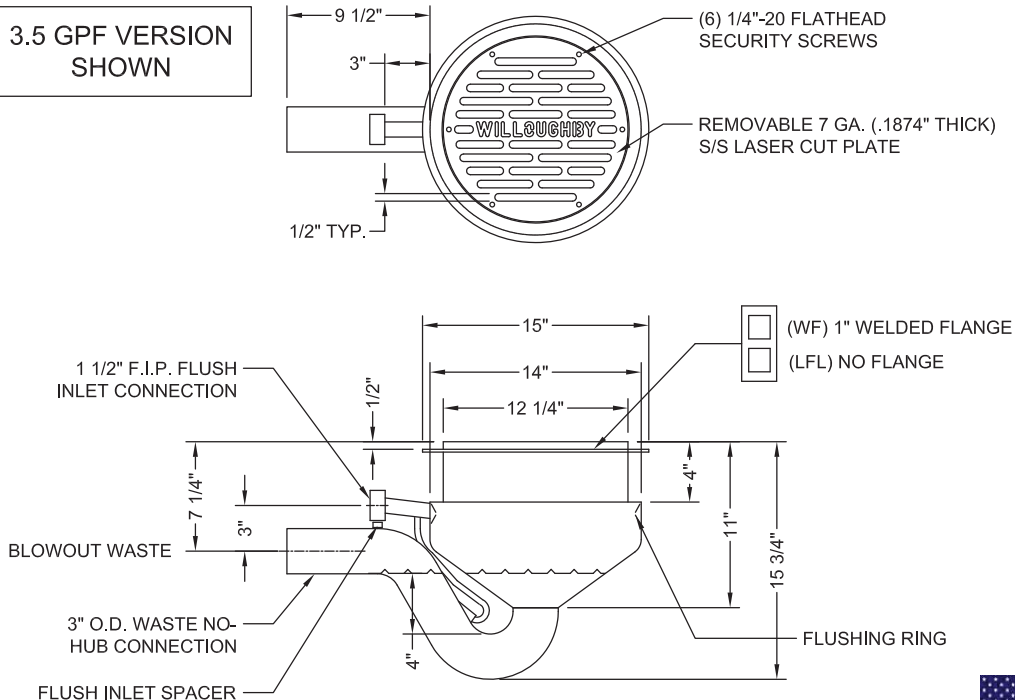

visit our website at [www.willoughby-ind.com](http://www.willoughby-ind.com)

5105 West 78th Street • Indianapolis, IN. 46268

(317) 875-0830 • Fax: (317) 875-0837 • (800) 428-4065



MADE IN THE U.S.A.