



PRESTIGE

I0073LF

Deck Mount Kitchen faucet Grifo de la cocina de la cubierta

Limited
LIFETIME WARRANTY
Garantía de por vida limitada

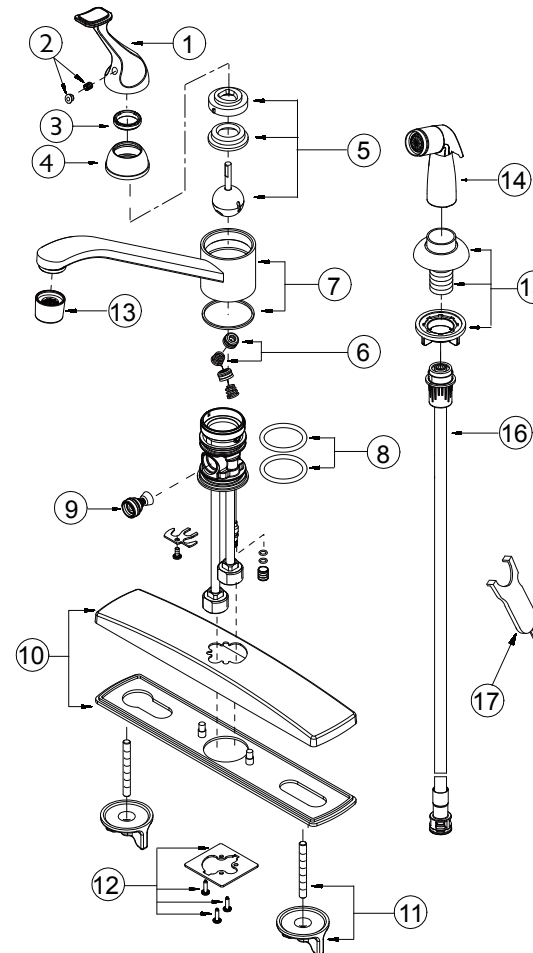

1.	Metal Handle/Manija metálica
2.	Index Button-Cold/Hot/Indicador de temperatura-caliente/fría
3.	Locking Nut/Contratuercas
4.	Trim Cap/Manija metálica
5.	Ball Valve Assembly/Conjunto de la válvula de bola
6.	Seat & Spring Set/Asiento válvula de bola
7.	Spout Set/Juego de pico
8.	O-Ring Set (1-1/4" ID - 1-1/2" OD)/Manija metálica
9.	Spray Diverter w/Vacuum Breaker/Manija metálica
10.	Cover Plate & Putty Plate/Cubierta & placa de masilla
11.	Mounting Hardware/Ferretería de montaje
12.	Base Mounting Hardware/Manija metálica
13.	Aerator/Aireador
14.	Side Spray/Rociador lateral
15.	Spray Holder Assembly/Rociador lateral
16.	Spray Hose/Manguera del rociador
17.	Wrench/Llave

These are general installation guidelines ONLY and are by no means comprehensive. Installation should be performed by a professional plumber. EZ-FLO International Inc. bears no responsibility for the improper installation or misuse of this product. These are only general recommendations.
Estas son guías de instalación SOLAMENTE y por ningún motivo son exhaustivas. La instalación debe ser realizada por un plomero profesional. EZ-FLO International, Inc. no se responsabiliza por la instalación inadecuada o mal uso de este producto. Estas son solo recomendaciones generales.

Genuine  Faucets

© 2016 EZ-FLO INTERNATIONAL, INC.
2750 E. Mission Blvd. - Ontario, California, USA 91761

Tools and supplies you will need the following to install your new faucet

Herramientas y provisiones que necesitara para instalar su nuevo grifo



adjustable wrench
llave inglesa

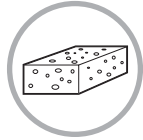

sponge or rag
esponja o trapo

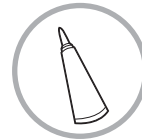

clear silicone latex caulk
sellador silicona-latex
transparente



10" groove
joint pliers
pinzas de junta
ranurada 10"



cross-head
screwdriver
desarmador de
estrella



pipe joint tape
cinta adhesiva
para tubería

Before You Begin:
Turn off water supply
Remove old faucet.

Antes de Comenzar:
Cierre el suministro de agua
Quite el grifo viejo.

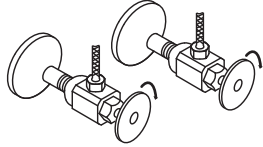

Close drain to avoid losing
small parts.

Cierre el desagüe para evitar
perder piezas pequeñas.

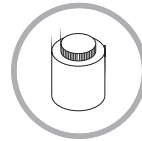

plumber's putty
plumber's putty



basin wrench
llave para lavabo

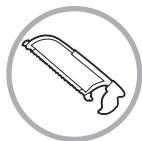

hacksaw
sierra



tube cutter
cortador de tubo

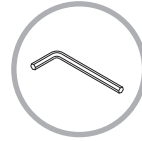

hex wrench
tornillo hexagonal



utility knife
navaja



pipe wrench
llave perica

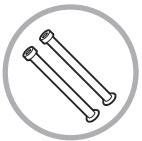

supply
mangueras
de abasto

Installation Instalación

1 Position new faucet.
Coloque el grifo nuevo.

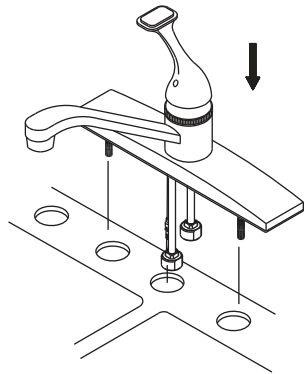

2 Insert spray holder through
fourth hole on sink. Screw
lock nut onto shank. /
Introduzca el soporte del
rociador por el cuarto orificio
en el fregadero. Atornille la
contratuercas en el vástago.

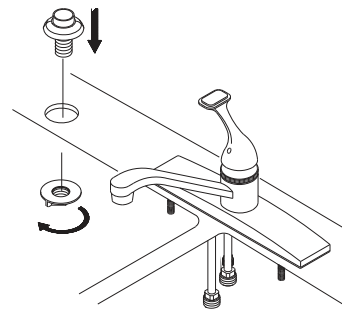

3 Screw and tighten lock nuts
onto faucet. / Aplique cinta
de teflón a las roscas de las
entradas.

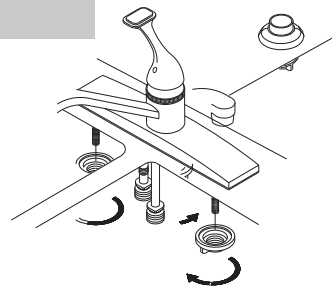

4 Attach mounting nuts
to inlet ports. / Attach
mounting nuts to inlet
ports.

6 Screw spray head onto
spray hose. / Atornille
la cabeza del rociador en
la manguera.

7 Attach water supply hoses or tubes to the faucet. To
avoid breaking the copper tube from the faucet, use
two wrenches (as shown) to keep from twisting the
supply tube from the faucet when you tighten the nut.
/ Instale en el grifo las mangueras o tubos de suministro
de agua. Para evitar dañar el tubo de cobre del grifo, use
dos llaves para mantener el tubo derecho al ajustar la
tuercas [ver ilustración].

8 After installing faucet, remove aerator and
turn on water to remove any left over debris.
Re-assemble aerator and tighten. / Después
de instalar el grifo, remueva el aireador y abra el
paso del agua para remover cualquier residuo.
Vuelva a armar el aireador y apriete.

Plastic SealCover / Cubier
ta obturadora de plástico

5 Insert spray hose down through hole in spray holder.
Remove the plastic seal cover from the outlet port
prior to pushing the hose adapter onto the same port,
you will hear a "click" sound once they are joined. / Pase
la manguera del rociador por el orificio en el soporte. Quite
la cubierta obturadora de plástico de la conexión de salida
antes de presionar el adaptador de manguera contra la misma
conexión; cuando se haya producido la conexión oírán un "clic".

